



INSTALLATION INSTRUCTIONS

**911-252P-N
QUICK SHIP 2 MODIFIED
3.5" WITH BRACKET (NO CLAMP)**

Please read the entire manual before beginning installation.



TAB SECTION INDEX

1. 3D AND 2D DRAWINGS
2. INSTALLATION GUIDE
3. INSTALLATION STEPS
4. COMPONENT INSTALLATION
5. APPENDIX
6. ORIGINAL COMPONENT MAINTENANCE FORMS
7. COMPLETED COMPONENT MAINTENANCE FORMS



Table of Contents

3D DRAWING 4
TOP DOWN VIEW 5
FOOTING VIEW..... 6
POST ID VIEW 7
Important 8
 When you receive your playground 8
 Before you begin 8
Safety Surfacing 10
Tools and Materials..... 11
BEFORE BEGINNING 12
 SITE REQUIREMENTS..... 12
 MAINTENANCE:..... 12
 PLAY AREA: 12
Installation Punch List 14
 Footing Layout Example 14
 Step 1: Layout..... 15
 Step 2: Holes 15
 Step 3: Deck, Post & Component Installation 16
 Step 4: Concrete..... 17
 Step 5: Last Step..... 17
 Four Hole Bracket & Panel Bracket Installation 18
 Other Installation Tips..... 19
SUPERVISION GUIDE 21

HARDWARE DRAWINGS

COMPONENT INSTALLATION INSTRUCTION SETS

APPENDIX

FINAL INSTALLATION STEPS

MAINTENANCE AND INSPECTION



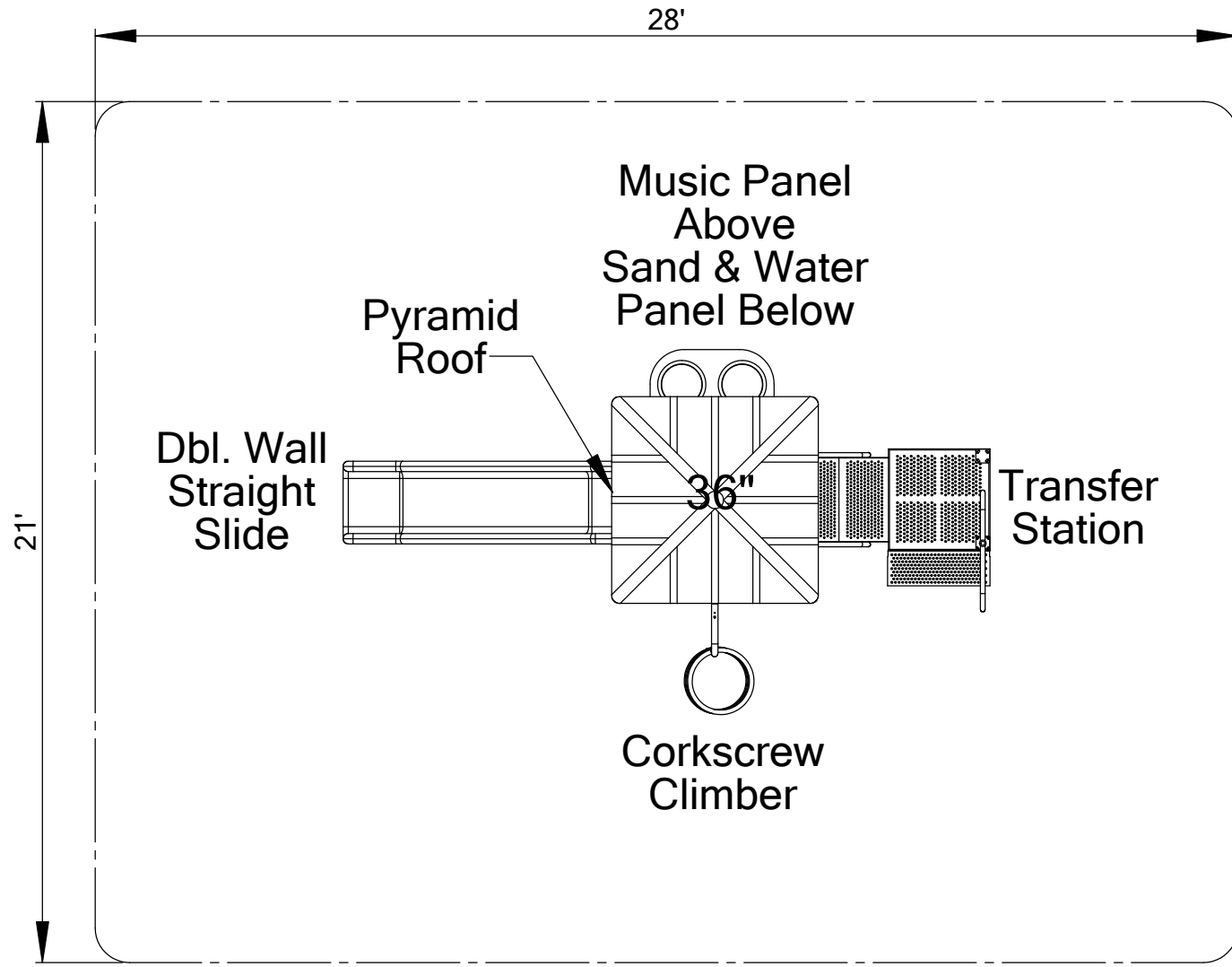

SportsPlay
800-727-8180
Fax: 314-389-9034
www.sportsplayinc.com

Size: 9' X 16'
Use Zone: 21' X 28'
Age Group: 2-12

Drawn By:	Date
E. Barron	00-00-10
CPSC: Compliant ASTM: Compliant	

Project: QS2_MOD
Drawing Number: #911-252 Distributor: SportsPlay
Scale: 1:50
Sheet 1 of 1

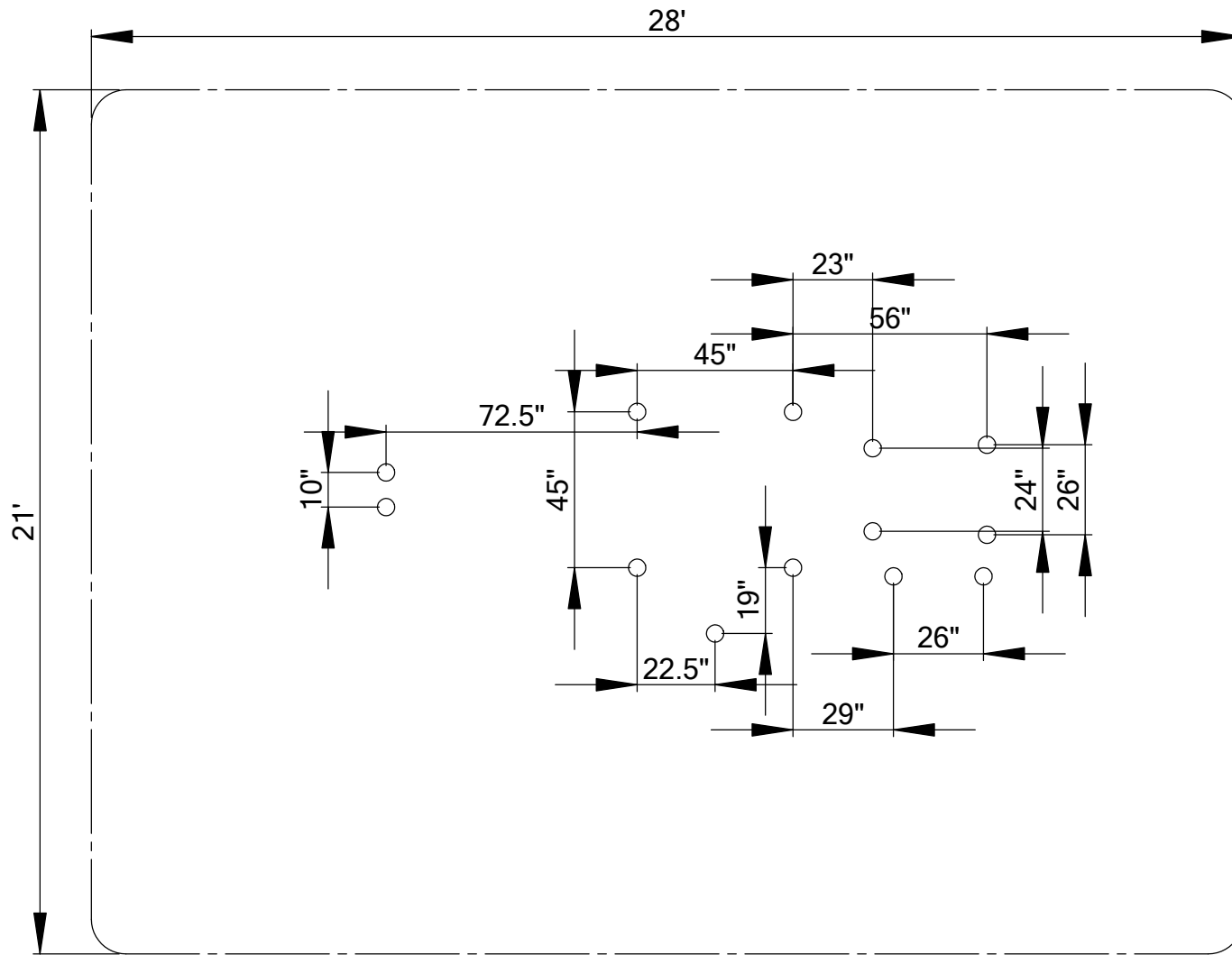

SportsPlay

800-727-8180
 Fax: 314-389-9034
 www.sportsplayinc.com

Size: 9' X 16'
 Use Zone: 21' X 28'
 Age Group: 2-12

Drawn By:

E. Barron

Date

00-00-10

CPSC: Compliant
 ASTM: Compliant

Project: QS2_MOD

Drawing Number: #911-252
 Distributor: SportsPlay

Scale: 1:50

Sheet 1 of 1

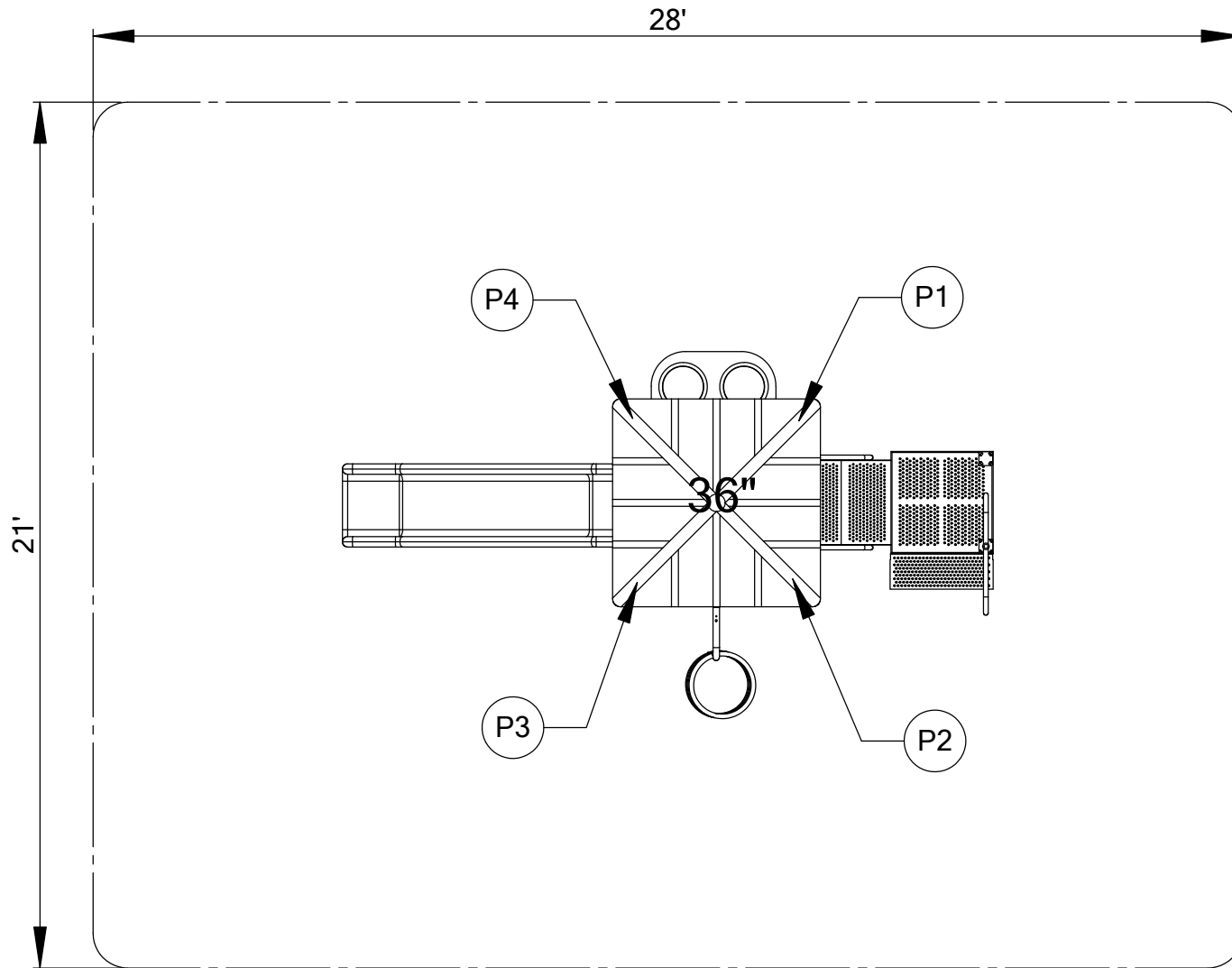

SportsPlay

800-727-8180
 Fax: 314-389-9034
 www.sportsplayinc.com

Size: 9' X 16'
 Use Zone: 21' X 28'
 Age Group: 2-12

Drawn By:

E. Barron

Date

00-00-10

CPSC: Compliant
 ASTM: Compliant

Project: QS2_MOD

Drawing Number: #911-252
 Distributor: SportsPlay

Scale: 1:50

Sheet 1 of 1



Value Series Installation Guide

Important

Please read completely before beginning installation.

This equipment has been designed for safety as well as challenge and fun. This equipment has been designed to reduce injuries and therefore must be installed “Step by Step” per our Instructions.

The U.S. Consumer Product Safety Commission (CPSC) published a report stating 79% of all playground injuries treated in U.S. Emergency Rooms was the result of a fall. It is critical that you refer to the Protective Surfacing section of these instructions, located on the next page prior to installing your playground. As the owner you are responsible for the safe installation of not only the play equipment, but also the safety of the site.

When your receive your playground

- Identify all parts by comparing them to the part list and component instruction pages.
- Always compare the number of pallets, cartons or other items the BOL has listed with the number actually received. Note the any discrepancies on the BOL.
- Also note any obvious damage to the packing materials, pallets or components on the BOL.
- Equipment should be inventoried and installed within a few days of receipt. The packing materials are meant to protect the equipment during shipping and not for storage. Heat, weather and sunlight can damage the packing materials, which can impact the components. If storage is required you must store the equipment in a controlled environment away from heat, moisture and sunlight. SportsPlay recommends carefully unpacking the unit and taking an inventory before

storing the equipment. Care should be taken with all powder coated and thermoplastic-coated parts to prevent damage to the coating. Additionally all plastic panels need to be stored flat to prevent warping.

- You have 30 days from receipt of your equipment to file a claim for missing or damaged parts.

Before you begin

Review your playground footing and top view drawings to ensure your site is large enough. The use zone for playground structures extends 6' (72") from its perimeter. Remember that you may not overlap the use zone of any slide with another playground. These guidelines are available from the CPSC (contact information for the CPSC is located on the next page).

- Read through the entire instruction booklet before beginning the actual installation.
- Before you begin preparing the site or digging any holes you must first contact you local utility companies so they can visit the site and mark all of the buried utilities. In the U.S. you may call 811 and your call will be routed to your local utility center.
- This equipment was designed to install on a clear and level site. There should be no more than 3" of grade variations in a 10' span.
- Footing layout is the first critical step once the installation begins. Mark all holes using the footing diagram. Prior to digging holes compare the measurements from the footing diagram to the actual site markings to ensure accuracy. Then check it again! (Footing info is located on pg 16 in this guide)
- Our posts are manufactured to accommodate 12" of protective surfacing.
- Evaluate the site for drainage. To ensure good drainage around the equipment consult a local professional.



Value Series Installation Guide

- Do not leave the jobsite un-attended during installation unless all access points to the play area are secure, all bolts and fasteners are tight and all ground holes are covered.
- SportsPlay Equipment inc. has provided two warning labels that state: “WARNING – Installation over a hard surface such as concrete, asphalt or packed earth may result in serious injury or death from falls.” These labels must be installed on vertical posts as per ASTM F1487. Instructions for the placement of these labels are included in the appendix of this booklet.
- SportsPlay will provide manufacturer identification labels that must be installed on the structure during installation per ASTM F1487. Installation instructions for these labels are included in the appendix of this instruction manual.
- Labels must be replaced when they are no longer legible. Contact your distributor for replacement labels.



Safety Surfacing

WARNING! – INSTALLATION OVER A HARD SURFACE SUCH AS CONCRETE, ASPHALT OR PACKED EARTH MAY RESULT IN SERIOUS INJURY OR DEATH FROM A FALL

Because accidental falls are likely to occur around play equipment, SportsPlay Equipment Inc. recommends that a resilient safety surfacing that will meet standard ASTM F1292 be placed under and around the structure and extend throughout the entire use zone.

SportsPlay Equipment Inc. does not manufacture safety surfacing. All manufacturers of safety surfacing require different depths of surfacing for fall heights. Consult your surfacing supplier about the required safety surfacing depth for your play equipment.

SportsPlay Equipment Inc. manufactures all playgrounds to accommodate 12” of safety surfacing. If you intend to adjust the height of the surfacing you will need to adjust the depth of the footing to accommodate the surfacing height.

Refer to the CPSC Handbook for Public Playground Safety for the recommended type and depth of the protective surfacing as well as all other playground safety concerns.

For a copy of the most current issue of the CPSC Handbook for Public Playground Safety, write to:

U.S. Consumer Product Safety Commission
Office of Information and Public Affairs
Washington DC, 20207
USA

Call - 1-800-638-2772 (US and Canada only)
Call - 301-504-0990
Direct Link - <http://www.cpsc.gov>

For a copy of either the standard for surfacing (ASTM F1292) or for play equipment (ASTM 1487) write to:

American Society for Testing and Materials
100 Bar harbor drive
West Conshohocken PA, 19428-2959
USA

Call – 618-832-9585

Web Site – www.astm.org

You must consider the type of safety surfacing you will use before beginning the installation process. There are two general types, organic/loose fill or synthetic unitary (pour in place). You must know which type of surfacing you are going to use prior to installing the playground. This unit was designed for 12” of loose fill surfacing so if the customer wants to use a synthetic unitary product that has a much smaller height than 12” you must dig the footing holes deeper to allow for the difference.

If loose fill surface material is to be used (example: wood mulch) you will need to consider containment borders. There are many products to choose from including hard plastic and natural products such as wood (Creosoted railroad ties are NOT recommended for use as borders in a play area). Loose fill materials are easily displaced so use of some type of containment border is necessary to keep the surfacing material inside the intended area. Some customers also prefer to have a weed mat installed to prevent weed growth. Choose a mat that will prevent growth but will also allow for drainage.



Tools and Materials

List is for tools and materials needed that are not included with the playground

Follow manufacturer's guidelines for proper use of tools and materials.

- The best method (also the easiest) to dig the postholes is using a tractor with a 12" auger attachment.
- Shovels (long handled spades)
- Post hole digger
- Wheelbarrow
- Large construction bar (5')
- Pry bar
- Claw hammer
- Large dead-blow rubber hammer
- Small sledgehammer to use in blocking the posts
- Vise grips (various sizes and styles)
- Strong and sturdy step ladders
- Socket set's (1/2" & 3/8" drive)
- Extension cords & power supply
- Drills (1/2" and 3/8")
- Drill bits and spade bits
- Levels – Magnetic torpedo and 4' long levels
- Scrap lumber to use for shims in post holes to keep posts level
- Blocking materials for the post holes (bricks, concrete blocks, etc.)
- 4' Bar Clamp
- Files and sand paper
- Safety surfacing
- Spray paint to mark holes
- String line
- Cement (2,500 psi minimum)
- Straight line or transit level (and tripod) for ensuring hole depths are at the same level



Value Series Installation Guide

**BEFORE STARTING INSTALLATION OF YOUR PLAYGROUND,
PLEASE READ INSTRUCTIONS THOROUGHLY.**

BEFORE BEGINNING

SITE REQUIREMENTS

The Playground system is designed to suit a level site. Should there be any falls or slopes on the site; care should be taken to accommodate the entry and exit points and to maintain the correct height. There should not be more than 3” of drop in grade per every 10’.

The site must be inspected for natural obstacles such as roots or rocks that may be a trip hazard, poor drainage and sharp objects such as glass.

Every state has different rules and regulations governing digging, some are stricter than others. In addition, 62 separate One Call Centers serve different areas of the country; now 811 will connect you directly to your local One Call Center. Prior to digging, be sure to call 811 or the local One Call Center to prevent accidentally disrupting local utility service.

MAINTENANCE:

As an owner, it is most important that you are aware of your responsibility to insure safe use of your new equipment. It is necessary to install equipment according to the installation instructions provided and inspect the equipment at regular intervals. During inspection, if any part is found damaged or excessively worn, equipment should be closed immediately. A maintenance section is included in the appendix of this instruction booklet.

If a part is missing or damaged the playground must be put out of service while the part is replaced. Lack of maintenance will result in premature wear, reduced life expectancy, and possible failure that may result in injury.

All SportsPlay Equipment play events have been engineered to meet all applicable safety guidelines, but if installed improperly, these problems may occur:

- Entrapment gaps (between 3 1/2” and 9”)
- String Entanglements
- Protrusions

Make sure that any bolt end that protrudes more than 2 threads past the face of the nut is trimmed and de-burred smoothly. Always double-check your work.

Installation must adhere to the manufacturer’s assembly manual and all other applicable safety guidelines.

PLAY AREA:

The area immediately above and around the play structure must be free of any obstructions such as:

- Trees
- Other Play Equipment
- Buildings
- Overhead Power lines

Make sure the play area has all the required safety surfacing and the minimum fall zones as required by the safety guidelines. These guidelines can be found at www.cpsc.gov.

CHILDREN MUST BE SUPERVISED AT ALL TIMES. No playground is safe without adult supervision!

There may be situations that require you to modify the layout or use your own judgment. If you have any questions contact your distributor.

Reading this entire manual before beginning the installation will help you to ensure your equipment is installed and maintained correctly.

The use zone for this equipment shall extend a minimum of 6’ in all directions from the perimeter of the equipment.



Value Series Installation Guide

The use zone for adjacent stationary equipment may overlap. If the deck height for that equipment **is no more than 30"** above the protective surfacing **the use zone is 6'**.

The use zone for adjacent stationary equipment may overlap. If the deck height for that equipment **is more than 30"** above the protective surfacing **the use zone is 9'**.

Installation Punch List

Footing Layout Example

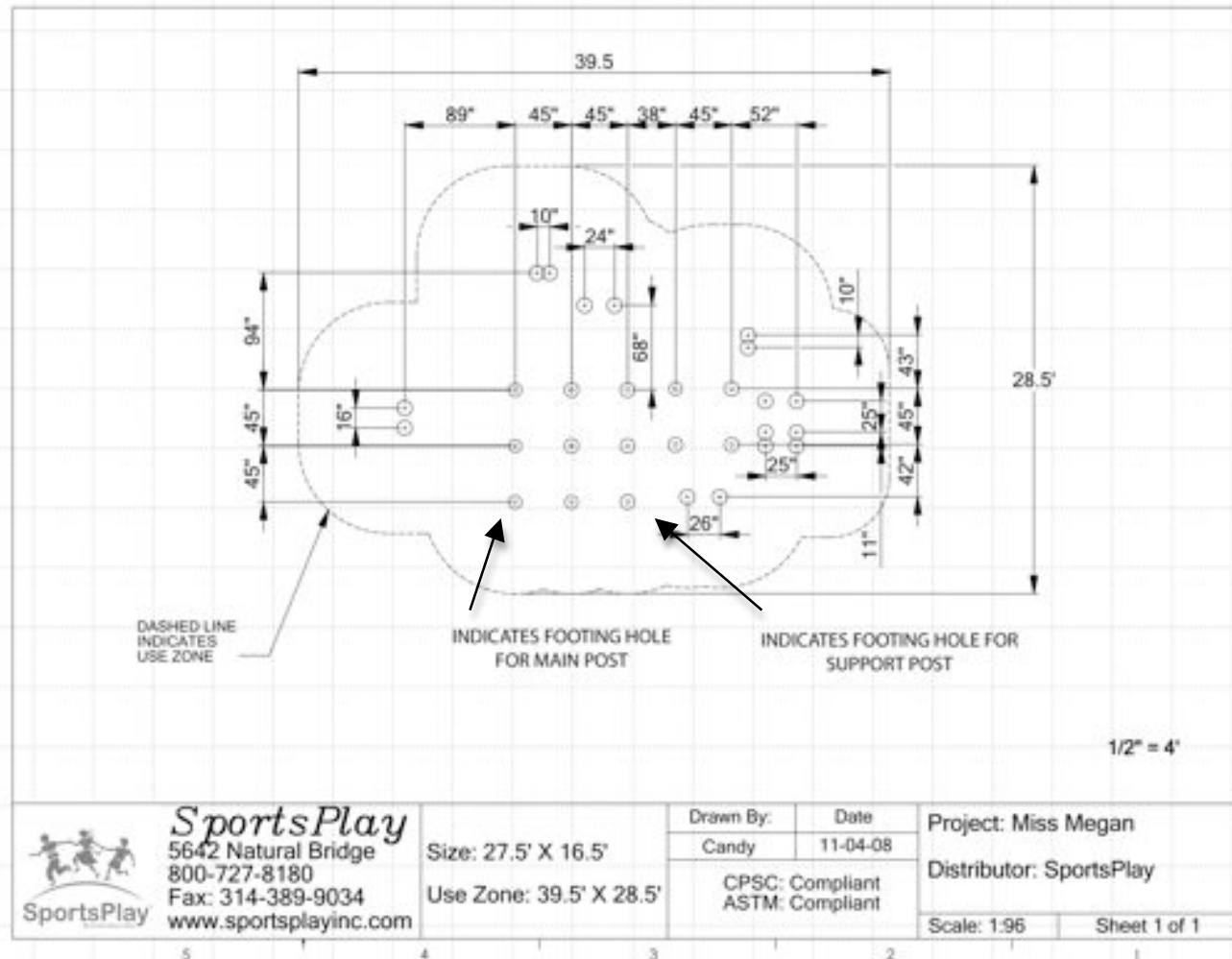

Step 1: Layout

1. Lay decks on ground in the desired location using the top view layout drawing. Measure from each deck to ensure there is adequate space for any component and the components fall zone. Below is an example of how to layout your decks so you can mark the location of the holes for the main posts and verify the required distance for a fall zone. This drawing is a standard drawing and does not represent the actual playground you are installing.

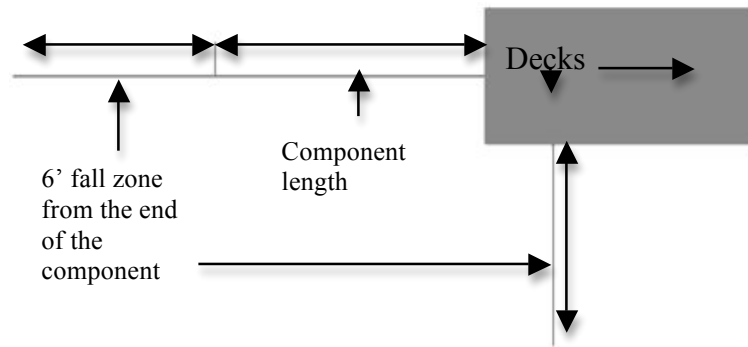

2. Most installers like to orientate the playground so that the entry point of the playground (primarily a transfer station) is facing either the sidewalk or the direction from which the children are entering the play area.

Step 2: Holes

1. If the site grade is not level you have to adjust the footing depth to maintain a level footing. Check with building codes to ensure you meet required hole depth and width. If a deeper footing is required you must add blocking materials to the hole to keep the post depth in accordance with the footing side view drawing on the next page.

2. Once the decks are in the desired location within the play area and the decks are flush with each other, mark the locations of the post by inserting a stake into the center of each post location (see drawing below for an example). If using spray paint to mark location please be careful not to spray the deck.

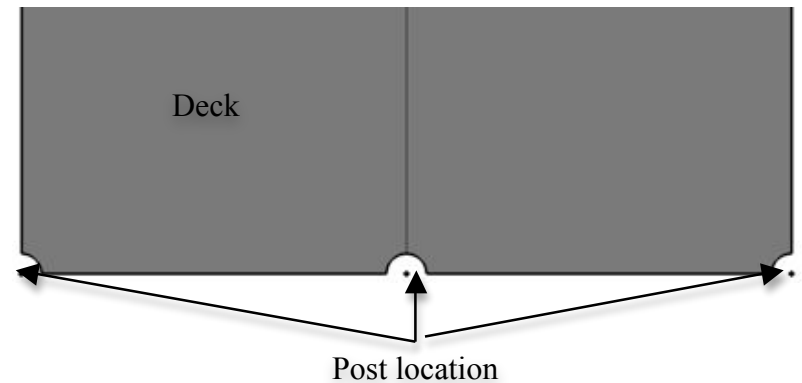

3. Match the post location marks with the footing layout in the front of this booklet (an example of how to identify which holes are for the main posts and which are for support posts is on the previous page). Dig your holes using the main post footing drawing below. If your surface grade is not level you should start with the lowest point and use that hole depth to level all other holes too. The footing drawing below indicates a depth of 22" plus the thickness of a brick (or the thickness of whatever blocking material you will use instead of a brick). This depth is for 12" of surfacing only. If you are using something other than 12" of surfacing, such as 3" of rubber your hole depth would have to be 31" plus the thickness of a brick to allow for less surfacing material. (Footing depths for support posts such as slide legs are listed in the component assembly instructions.)

FOOTING SIDE VIEW

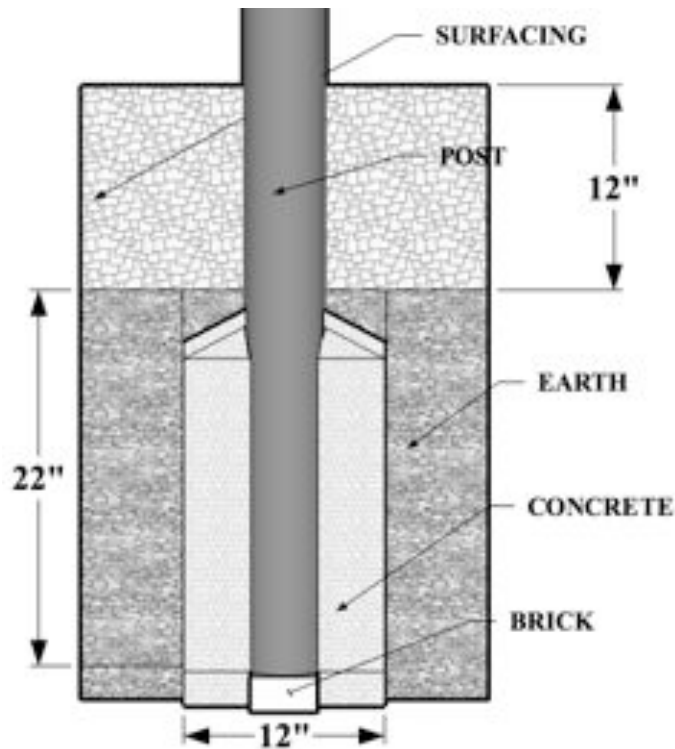

4. It is recommended that you use a transit to level the remaining postholes to the first hole in order to ensure that the posts are level.
5. Using the post identification drawing (4th page of this booklet) identify which post goes in each hole by matching the number on the post with the number on the drawing.

Step 3: Deck, Post & Component Installation

1. The easiest way to install the playground is by starting with the central deck and then work out. We recommend installing the posts and central deck and once the post and deck are square and level you may add the concrete (concrete with a minimum of 2,500 psi should be used). Mix concrete per manufacturers instructions and let it cure for at least 24 hours before continuing.
2. **NEVER LEAVE THE INSTALLATION SITE UNATTENDED WITHOUT ROPING OFF THE AREA AND EQUIPMENT, INSTALLING ALL HARDWARE, SECURING TOOLS AND EQUIPMENT, AND COVERING OPEN HOLES WITH A RIGID MATERIAL (PLYWOOD). CHILDREN WILL TRY TO USE THE EQUIPMENT EVEN THOUGH ITS NOT FULLY ASSEMBLED. YOU MUST TAKE ACTION TO PREVENT INJURY AND DAMAGE.**
3. Once the first deck is installed and the concrete has set for 24 hours you can install the remaining decks working out from the first deck ensuring all decks and posts are square and level as you go.
4. Level and plumb all posts and decks and then brace them in position.
5. Beginning at the lowest deck, install all playground components. When installing the four hole brackets be sure to orientate the bracket so that the setscrew faces down. Use the footing layout at the beginning of this booklet to layout your component holes. Once the entire playground has been installed and the entire unit is level you may start adding the concrete.



Step 4: Concrete

1. Verify all posts, decks and components are tight, level and square. Once the unit is verified to be level and square you may start installing concrete. You must use concrete with a minimum of 2,500 psi.
2. Always pre mix the concrete to the manufactures directions before pouring it into the hole. Never put dry concrete in the hole. Typically each main posthole requires two 80-pound bags of concrete.
3. Allow concrete to set in accordance with manufacturers directions. Fill holes too about 2” below the surface with concrete. Once the hole has been filled with concrete, slope the top of the concrete down and away from the post to keep water from seeping between the post and the concrete.
4. Secure playground area to prevent access while the concrete is setting for a minimum of 48 hours.
5. SportsPlay recommends having a CPSI (certified playground safety inspector) present during installation. If that’s not possible you should have the completed playground (after surfacing is in place) inspected by a CPSI.

Step 5: Last Step

1. After concrete has completely set, backfill all holes with dirt.
2. Install surfacing label, 12” from dirt surface on main posts for mulch.
3. Install surfacing.

Four Hole Bracket & Panel Bracket Installation

Tip for installation

- Use the #7 drill bit to pre-drill all holes when connecting the bracket to the post if you are having trouble with the self-tapping screws

Installation

- Always install the brackets with the set screw facing down (refer to the drawing on the right)
- Always install the rubber gasket with the brackets
- After you have installed the brackets and the component completely verify the set screw is tightly in place and smooth out all sharp edges and points
- Use the screw bit included with the hardware
- Do not over tighten screws



FOUR HOLE
ATTACHMENT
BRACKET

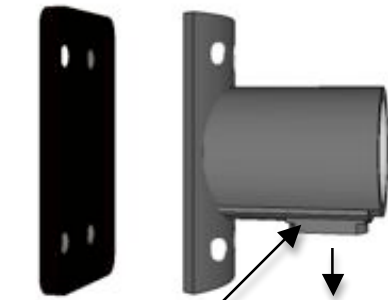

Set screw facing
down

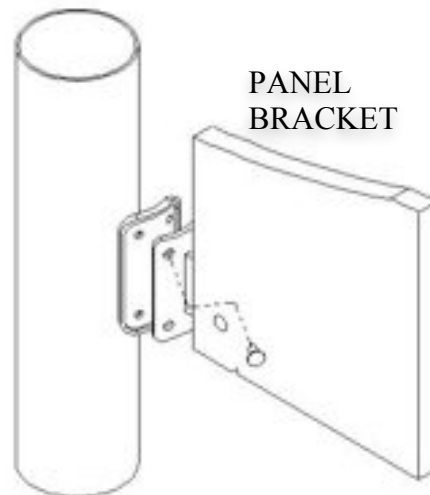

PANEL
BRACKET

Direct Bolt Deck

While two people position and hold the deck in place, insert the deck bolt and washer through the deck and into the factory installed nut on the post.

To ensure proper placement, refer to the layout drawing and the post id drawing at the beginning of this guide.

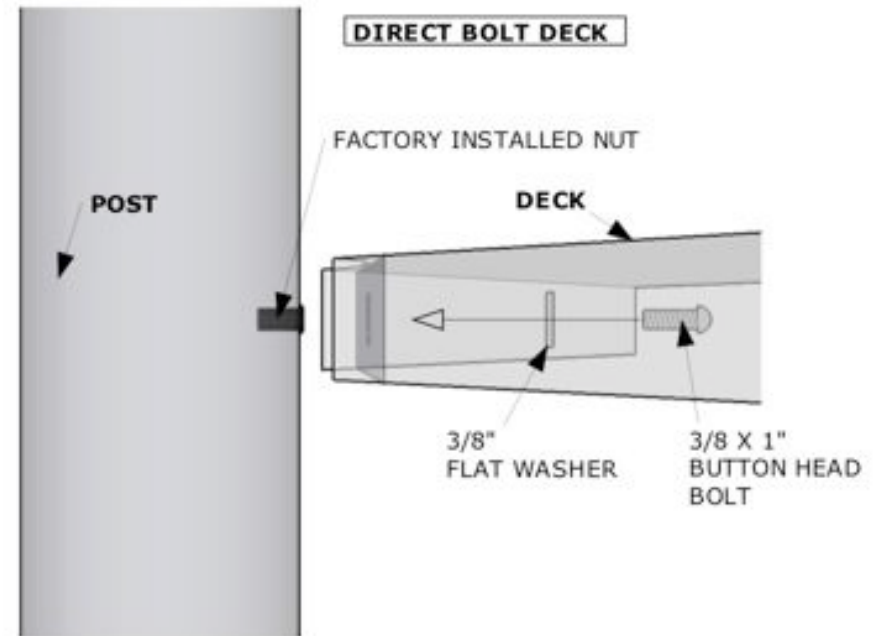
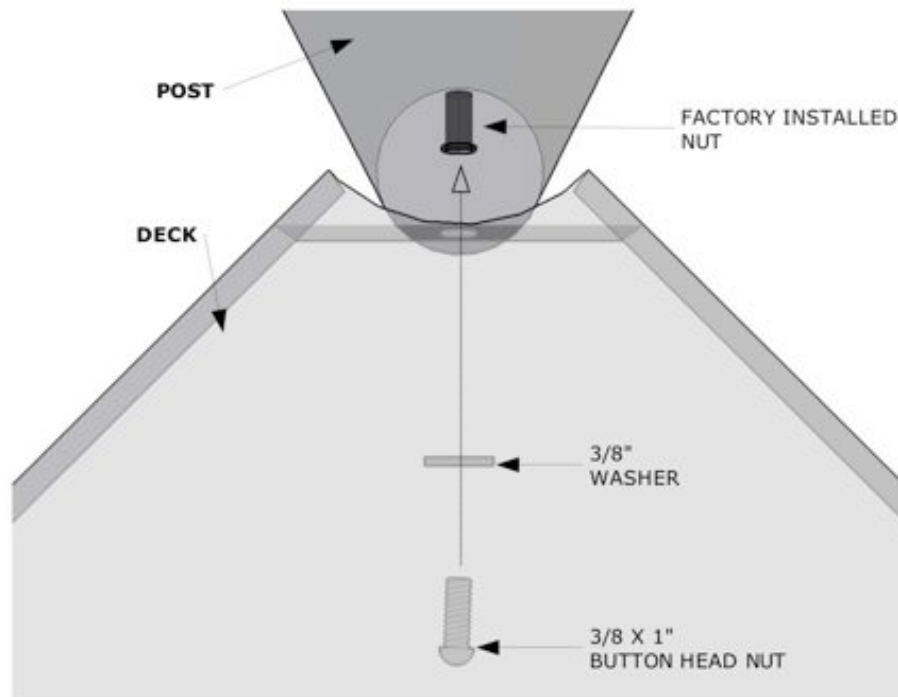



Other Installation Tips

- **When attaching a deck to a post** sometimes the factory installed nuts will spin when tightening the bolt. If this happens simply slide a slim flathead screw driver in between the deck and the post and slightly pry on the installed nut to keep it from spinning.
- **If you are mocking up components with the intention of removing the hardware at some point**, you may want to apply lubricating oil to the hardware. Stainless steel hardware has a tendency to seize so if you are planning on removing the hardware you may want to apply lubricant to prevent this.
- **Pre-drill the holes for the four hole bracket** in the posts with the #7 drill bit included with the hardware
- Unless specified in the specific component instruction step, **do not tighten the hardware completely** until the entire unit is assembled.



SUPERVISION GUIDE

Although the equipment is designed, installed and maintained in accordance with all safety guidelines adult supervision is required.

Not all equipment is appropriate for all ages. Direct children to age appropriate equipment.

Younger children will require more supervision than older children.

While eliminating accidents is not likely, following these guidelines will help minimize accidents.

Basic playground safety for supervisors:

- Make sure all safety surfacing is in place and at the correct height. Inspect area for hard or sharp objects and remove them.
 - No dangerous horseplay in the play area. (Jumping from dangerous heights, displacing of surfacing, etc...)
 - Inspecting for missing or broken equipment. (Do not allow children to play on broken equipment or equipment with missing components).
 - Make sure there are no unsafe modifications (especially ropes tied to equipment). Remove all unsafe modifications and close the equipment for play until they are removed.
 - Keep children in the designated play area.
 - Do not let children play on wet equipment.
 - Prevent overcrowding on play equipment.
- Loose clothing, hoods, strings or jewelry shall be tight or not worn while playing to prevent strangulation.
 - Ensure the temperature of the equipment is not hazardous. Direct sunlight exposure can increase the temperature of the equipment high enough to cause injury.
 - Inspect the playground every day using the General Inspection Checklist located in the appendix of this manual
 - The easiest method for performing the daily inspection with the checklist is to laminate the checklist and use a dry erase marker to mark the items off before opening the play area



COMPONENT INSTALLATION INSTRUCTIONS

INSTALLATION DETAILS

- Recommended crew (Adult): 3
- Installation time: **15 min (.75 man hr)**
- User age: **2-12**
- Use zone: **72"**
- Weight: **79**

SURFACING: Use of safety surfacing in compliance with ASTM specification F1292 is required.

MAINTENANCE:

- As the owner of the playground you are responsible for maintenance of the equipment and play area. A maintenance schedule must be developed and the equipment inspected frequently. A maintenance section that includes component specific maintenance requirements is included at the end of this manual.
- Be sure to inspect surfacing for foreign objects that could cause injury and that sufficient surfacing are in place in accordance with ASTM and CPSC standards.

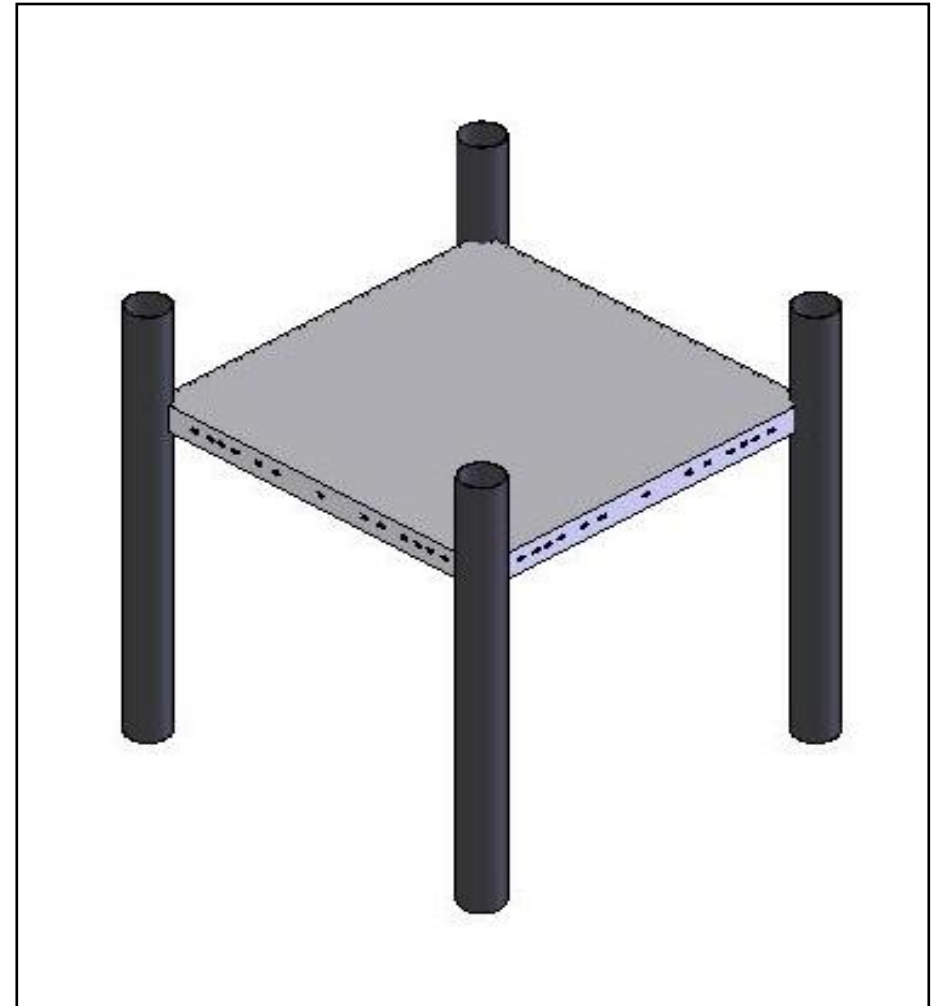

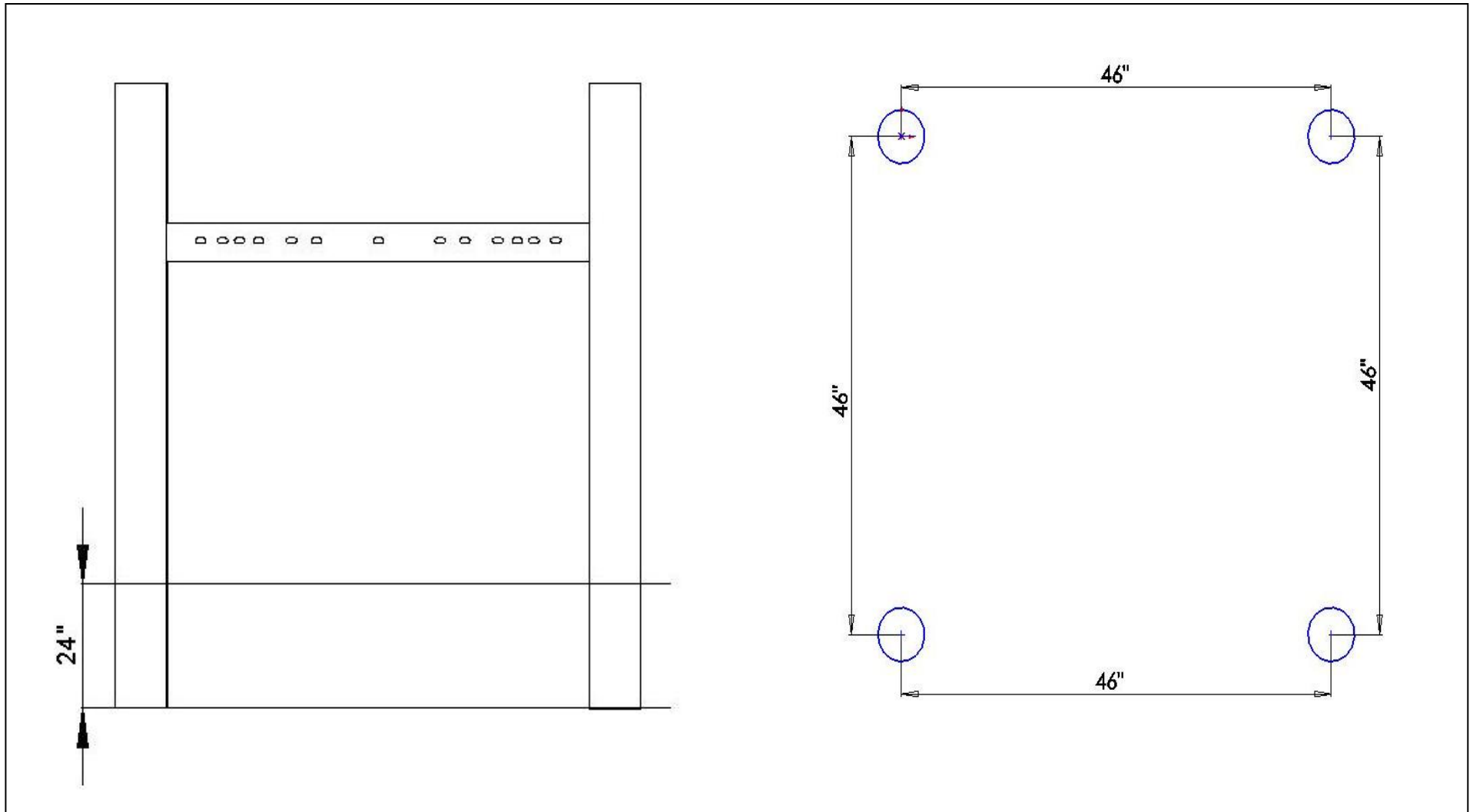



SPECIFICATIONS

- Deck-12 GA HRPO steel
- Hardware – Stainless steel & tamper resistant
- Paint – Electrostatically applied & oven cured thermoplastic powder coat

INSTALLATION TIPS & TROUBLE SHOOTING

- Should the factory installed nuts on the posts start spinning while trying to attach the decks, simply insert a flat head screw driver under the lip or the nut and tighten the bolt.
- Apply locktite to all bolts during assembly prior to completely tightening them.
- Stainless Steel hardware can occasionally be difficult to use particularly if you need to take them out to make an adjustment. It is recommended that you add a drop of oil to bolts that may have to be removed before you install them.
- Do not tighten bolts all the way until the unit is completely assembled and all components are square and level.
- Identify and separate all parts by referencing the detail drawings and the parts list.
- As you unpack and separate the components use the cardboard sheets that were used for packing and shipping to prevent damage to the components. This is particularly true all Powder Coated and Thermoplastic coated components, by setting the components on top of the cardboard.

BEFORE YOU BEGIN

In addition to the components on the packing list you will need a level and blocking material.

INSTALLATION STEPS

__1) **Review all instructions before beginning**

__2) **Unpack, organize, and identify all components:** Be sure to place all painted components on a protective surface (cardboard, cloth, etc...) to prevent damage.

__3) **Locate placement of the Square Deck:** See top down view of your instruction booklet

__4) **Attach Square deck to post:** Using one 3/8"x1 1/2" Button Head Bolt (2), with one 3/8" Flat Washer (3) installed on the bolt, inserts it through the factory punched slot in the Square deck. The bolt then threads into the factory installed nut in the post that the deck connects to. Repeat this step for all corners of the square deck.

__5) Once the entire playground has been installed and you have verified that the entire playground is level you can **add the concrete to the footing holes.** Be sure to use concrete with a minimum 2,500 psi and mix the concrete per the manufacturer's directions before you pour it into the footing hole. Once the footing has been filled with concrete you should rope of the area for a minimum of 48 hours to allow the concrete set properly.

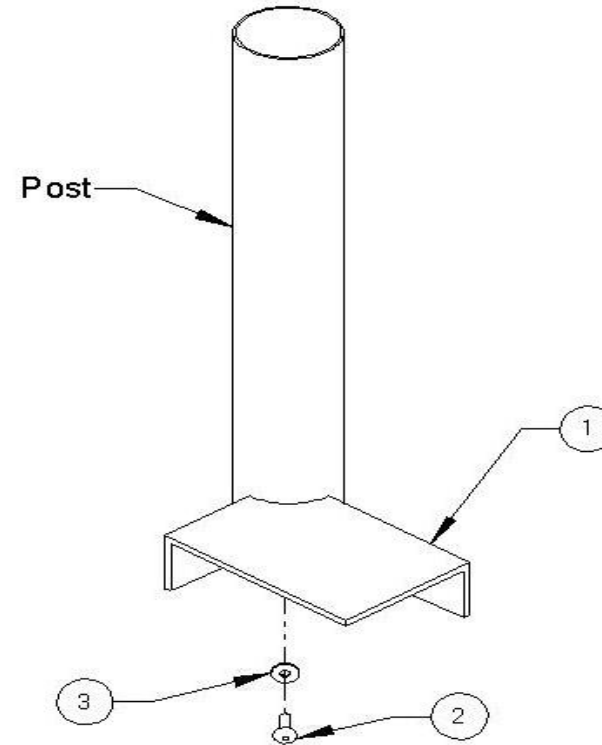



INSTALLATION STEPS CONTINUED

__6) **Once the concrete has set**, back fill dirt over the footing holes; inspect the area and components for tools, hazardous debris and sharp edges. Verify all components are installed and all hardware is tight and then install the safety surfacing.

__7) **inspect the components:** for sharp edges and if necessary file them down and apply touch up paint

INSTALLATION DETAILS

- Recommended crew (Adult): 2
- Installation time: **1.5 hr (3 man hrs)**
- User age: **2-12**
- Use zone: **72" from all edges of deck**
- Weight: **165 lbs**

SURFACING: Use of safety surfacing in compliance with ASTM specification F1292 is required.

MAINTENANCE:

- As the owner of the playground you are responsible for maintenance of the equipment and play area. A maintenance schedule must be developed and the equipment inspected frequently. A maintenance section that includes component specific maintenance requirements is included at the end of this manual.
- Be sure to inspect surfacing for foreign objects that could cause injury and that sufficient surfacing is in place in accordance with ASTM and CPSC standards.

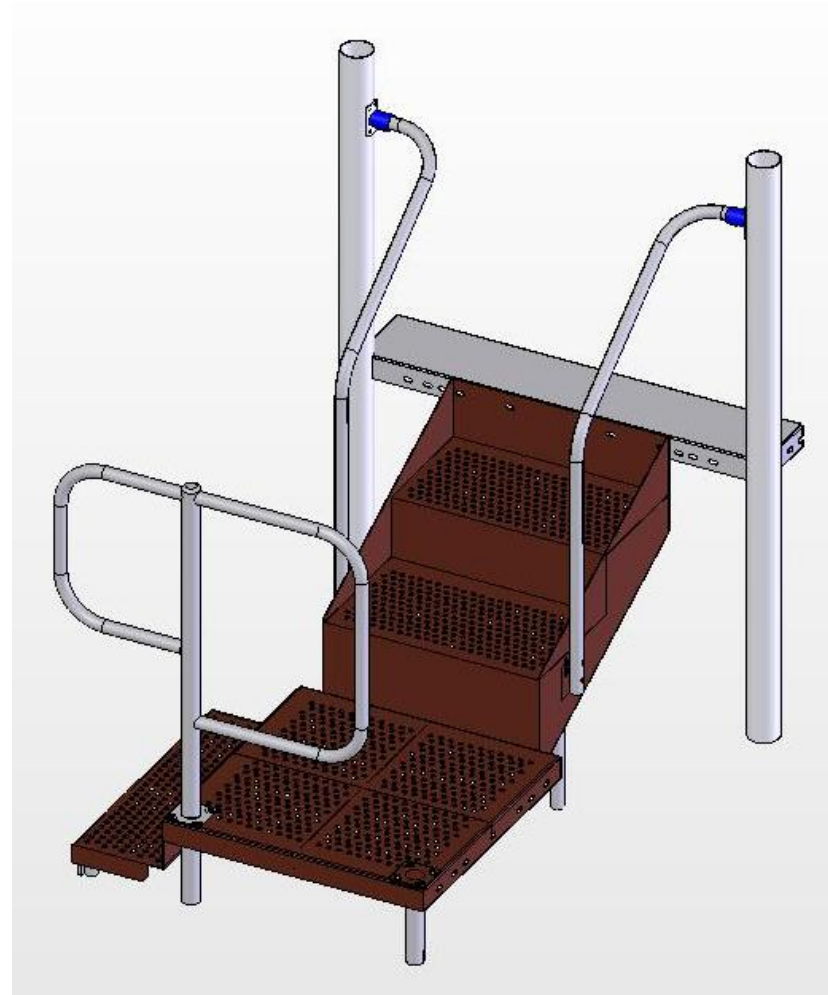

PARTS LIST

ID	PART #	DESCRIPTION	QTY
1	923-206	3' Transfer Station Stairs	1
2	923-211	Transfer Station Platform	1
3	923-210	Transfer Station Step	1
4	923-209	Transfer Station Cover Plate	1
5	923-208	Transfer Station Support Post	1
6	913-230	Transfer Point Inside Leg	4
7	913-426	Transfer Point Handhold Post	1
8	913-202	Transfer Point Handrail Left 3'	1
9	913-203	Transfer Point Handrail Right 3'	1
10	126-703	3/8"x1" Button Head Bolt	12
11	126-701bps	3/8"x 1 1/4" Button Head Bolt	10
12	316-601	3/8" Flat Washers	54
13	226-602	3/8" locknut	27
14	126-709bps	3/8"x 2 1/2" Button Head Bolt	4
15	913-402	Four Hole Attachment Bracket	2
16	905-208	Gasket for Attachment Bracket	2
17	905-526	Self Tapping Screw	8
18	106-807	3/8"x3/8" Set Screw	2
19	126-705	3/8" x 2" Button Head Bolt	2

NOTE: Keep a copy of these instructions on file to assist you with maintenance and replacement parts.

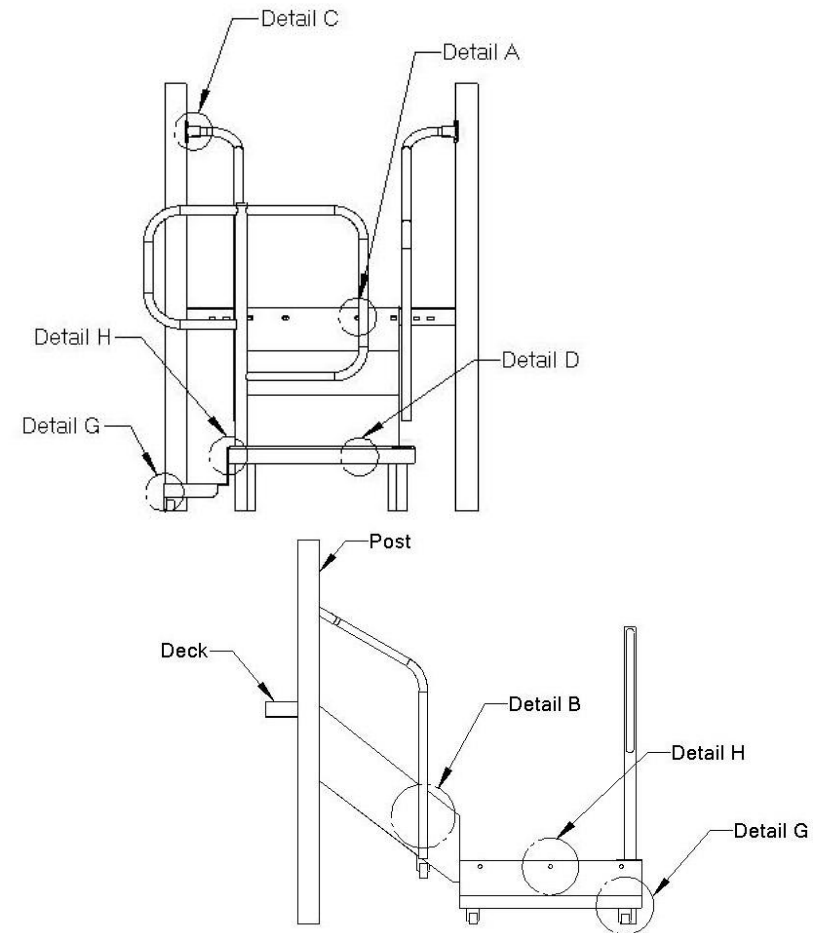

FOOTING INFORMATION

- Total footing depth is 24" less the height of the surfacing plus the height of the blocking material. If you are using 12" of surfacing the footing hole would need to be 12" plus the height of the blocking material (refer to both the side and front cutaway views to the right).
- If the Play structure is installed on an unlevel grade you must adjust the footing depth to accommodate the grade. For instance, if the grade for this component is 1" higher than the surface grade of the main playground post you must dig your footing hole 1" deeper.
- You must place the bottom of the support post or slide leg on a suitable flat blocking material to prevent it from sinking further into the soil. We recommend you use a brick, block of wood or several inches of gravel. The footing depth does not include this blocking material since materials used often vary.
- It is the owner/installers responsibility to check local building codes and to comply with those codes. All footing depths listed here are recommendations and local soil types and frost lines may require a deeper and/or wider footing depth. If that's the case you must add more blocking material to accommodate the deeper footing, as the post length will still only be installed at the depth listed in this instruction manual.
- Assemble the entire unit before adding the concrete unless instructed to do so in the individual component instruction sections.

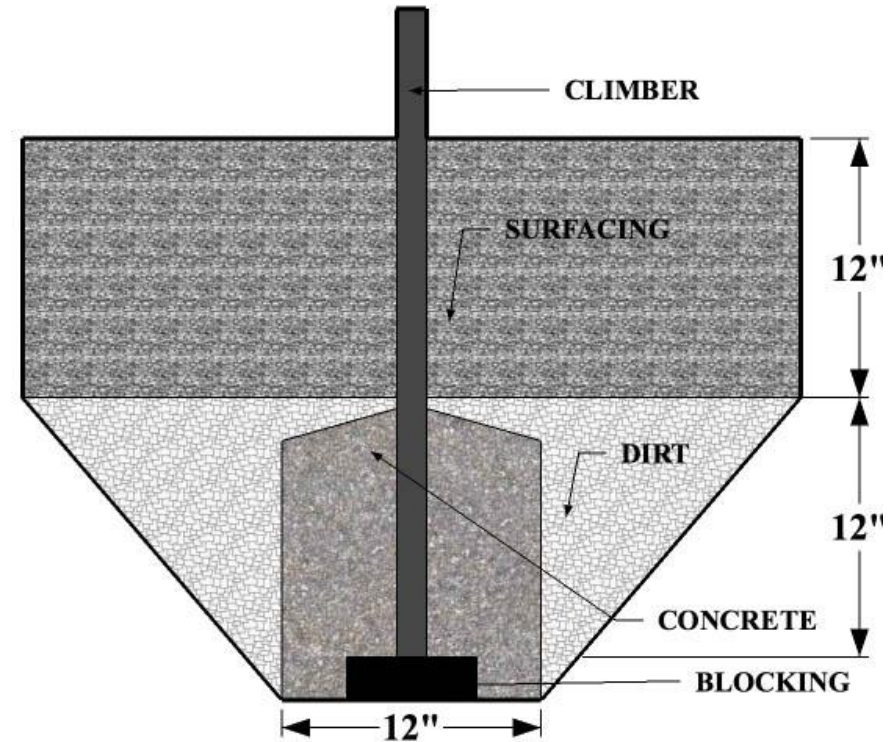

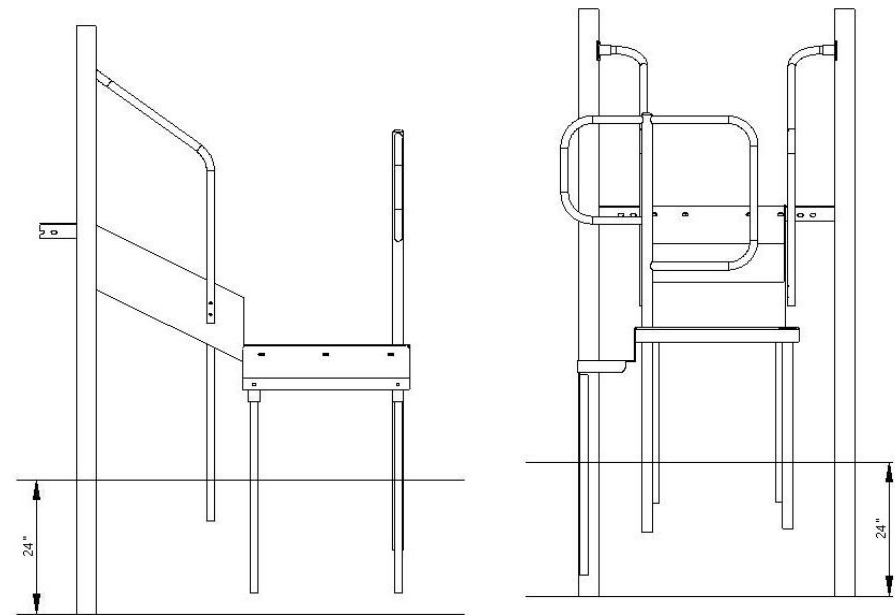
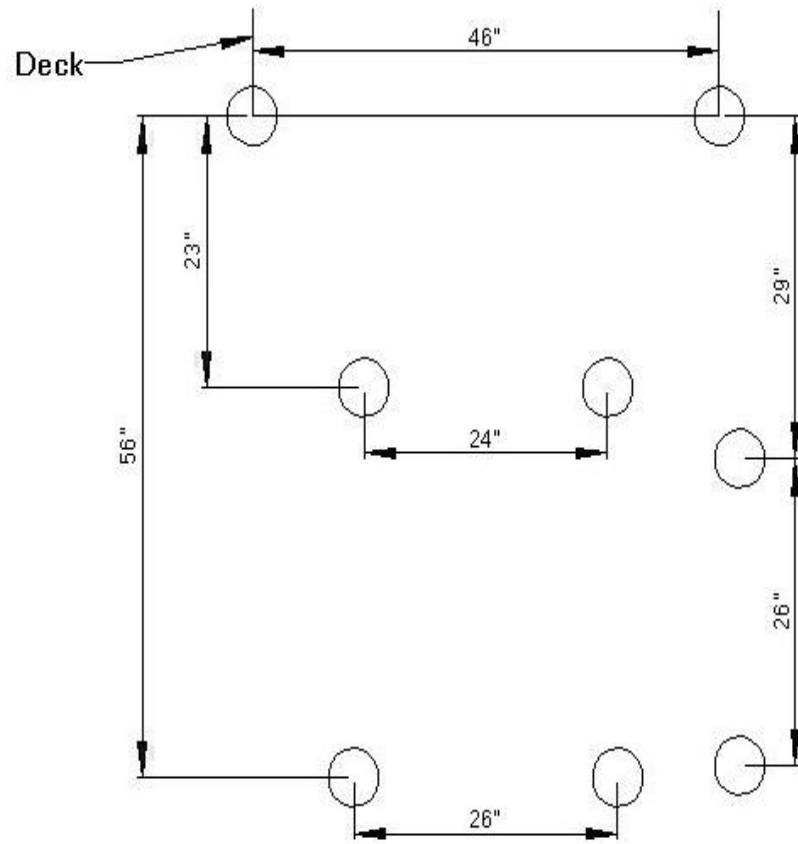



SPECIFICATIONS

- Deck and Steps-12 GA HRPO steel
- Deck & Step Coating – Electrostatically applied & oven cured thermoplastic powder coat.
- Tube – NEED SPECS
- Tube Paint – Electrostatically applied & oven cured powder coat
- Hardware – Stainless steel & tamper resistant
- Attachment Bracket – Powder coated cast aluminum

INSTALLATION TIPS & TROUBLE SHOOTING

- SportsPlay Equipment Inc. recommends pre-drilling the holes in the post when attaching a four-hole bracket with a number #7 drill bit. This will make the attachment of the four-hole bracket with the self-tapping screws easier and it will prevent damage to the screw head during installation.
- Apply loctite to all bolts during assembly prior to completely tightening them.
- Stainless Steel hardware can occasionally be difficult to use particularly if you need to take them out to make an adjustment. It is recommended that you add a drop of oil to bolts that may have to be removed before you install them.
- Do not tighten bolts all the way until the unit is completely assembled and all components are square and level.
- Identify and separate all parts by referencing the detail drawings and the parts list.
- As you unpack and separate the components, use the cardboard sheets that were used for packing and shipping to prevent damage to the components. This is particularly true all Powder Coated and Thermoplastic coated components, by setting the components on top of the cardboard.

BEFORE YOU BEGIN

In addition to the components on the packing list you will need a level, blocking material, 9/16 wrench, shovel, tape measure and a post hole digger.

INSTALLATION STEPS

- __1) Review all instructions before beginning**
- __2) Unpack, organize, and identify all components:** Be sure to place all painted components on a protective surface (cardboard, cloth, etc...) to prevent damage.
- __3) Locate placement of the Transfer Station:** See top down view at the beginning of your instruction booklet.
- __4) Dig Footing Holes:** Refer to the Footing Diagram on page 4 of this instruction set.
- __5) Install Transfer Station Stairs:** The Transfer Station Stairs (1) will connect using four 3/8"x 1 Button Head Bolts (10), eight 3/8" Flat Washers (12), and four 3/8" Locknuts (13). Place One 3/8" Flat Washer on to each of the four 3/8"x 1 Button Head Bolts. Insert the Bolt and Washer assembly through the top holes of the stairs, then through the factory punched hole in the deck that the Transfer Station installs to. (See detail A) Secure this with a 3/8" Flat Washer and Locknut. Do not tighten the Locknut until the stairs are level. Repeat these steps until all four bolts are installed in the stairs. After the bolts are installed, level and block the stairs. Now you can tighten the four bolts to secure the stairs.

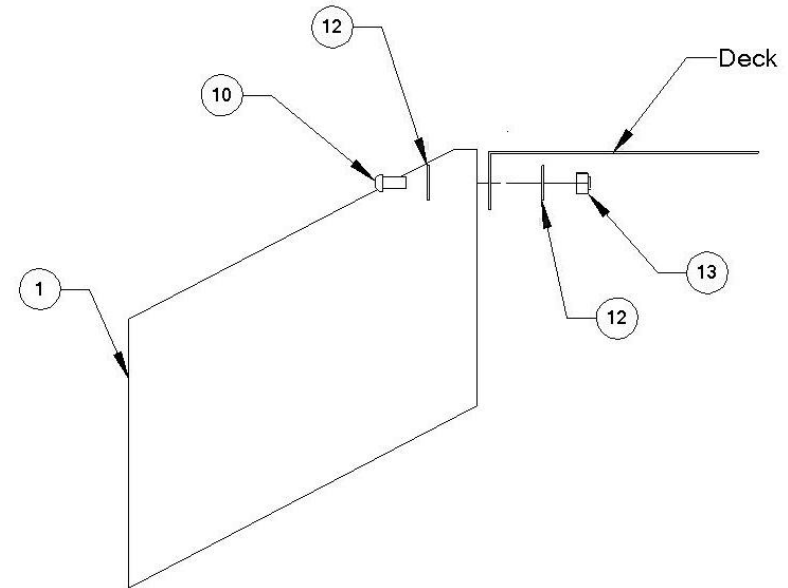

INSTALLATION STEPS CONTINUED

6) Install Handrails And Inside step Legs: You will need both the Left (8) and Right (9) Handrails, two Inside Step Legs, four 3/8" x 2 1/2" Button Head Bolts, eight 3/8" Flat Washers, four 3/8" Locknuts, two Four Hole Attachment Brackets (15), two Gaskets for Attachment Brackets (16), eight Self tapping Screws (17), and two 3/8" x 3/8" Set screws. Place one 3/8" Flat Washer on to each of the 2 1/2" Button Head Bolts. Insert this through the bottom hole on the Handrail, then through the bottom hole in the side of the stair. Now place the step leg into the footing hole and onto the 3/8" x 2 1/2" Button Head Bolt, the flat side of the inside step leg should touch the inside of the Transfer Station Stairs. Secure this with a second 3/8" Flat Washer and 3/8" Locknut. (See detail B) Install a second 3/8" x 2" Button Head Bolt and 3/8" Flat washer into the top hole of the Handrail. Place one of the Four Hole Attachment Brackets on the bent end of the Handrail and mark the holes on the post that it connects to. Drill the holes and install the Four Hole Attachment Bracket to the post. With the hole in the Four Hole Attachment Bracket facing the ground, attach it to the post using four Self tapping Screws, the Attachment Bracket Gasket will install between the Bracket and the post. Now you need to install the 3/8" x 3/8" set screw into the threaded insert in the Four Hole Attachment bracket to secure the Handrail to the post. (See detail C) Repeat this for the other handrail.

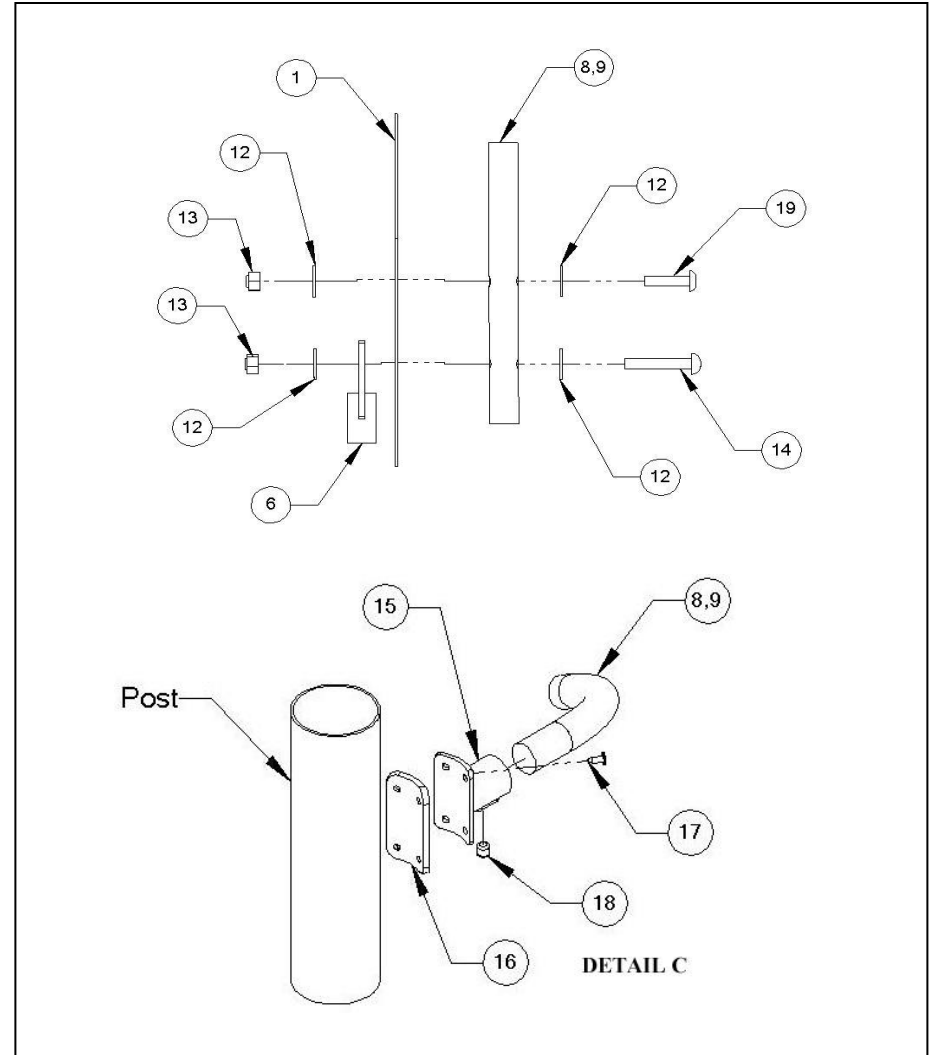

INSTALLATION STEPS CONTINUED

7) Install Transfer Station Platform: This will install to the bottom part of the Transfer Station Stairs. To do this you will need the Transfer Station Platform (2), Transfer Station Cover Plate (4), Transfer Station Support Post (5), Transfer Point Handhold Post(7), four 3/8" x 1" Button Head Bolts (10), eight 3/8" x 1 1/4" Button Head Bolts (11), twenty Four 3/8" Flat washers (12), and twelve 3/8" Locknuts. First start by placing a 3/8" Flat Washer onto each of the 3/8" bolts. Now you can attach the transfer Station Platform to the Transfer Station Stairs. Insert one of the 3/8" x 1" Button Head Bolts into one of the factory punched holes in the Transfer Station Platform. Now you can place the bolt through the Transfer Station Stairs and secure it with a 3/8" Flat Washer and 3/8" Locknut. (See detail D) Do not tighten these bolts until the deck has been leveled. Next place the Transfer Station Support Post into the footing hole opposite of the desired location of the Transfer Station Step. Place one 3/8" Flat Washer onto each of the 3/8" x 1" Button Head Bolts and insert them into the Transfer Station Cover Plate through the Transfer Station Platform and Transfer Station support post, then secure the four 3/8" x 1" Button Head Bolts with a 3/8" Flat Washer and 3/8" Locknut on each bolt. (See detail E) Now you will need the Transfer Station Handhold Post. It will drop through the transfer Station Platform and into the footing Hole. Use the remaining four 3/8" x 1" Button Head Bolts, 3/8" Flat Washers, and 3/8" Locknuts to secure it to the Transfer Station Platform. (See detail F)

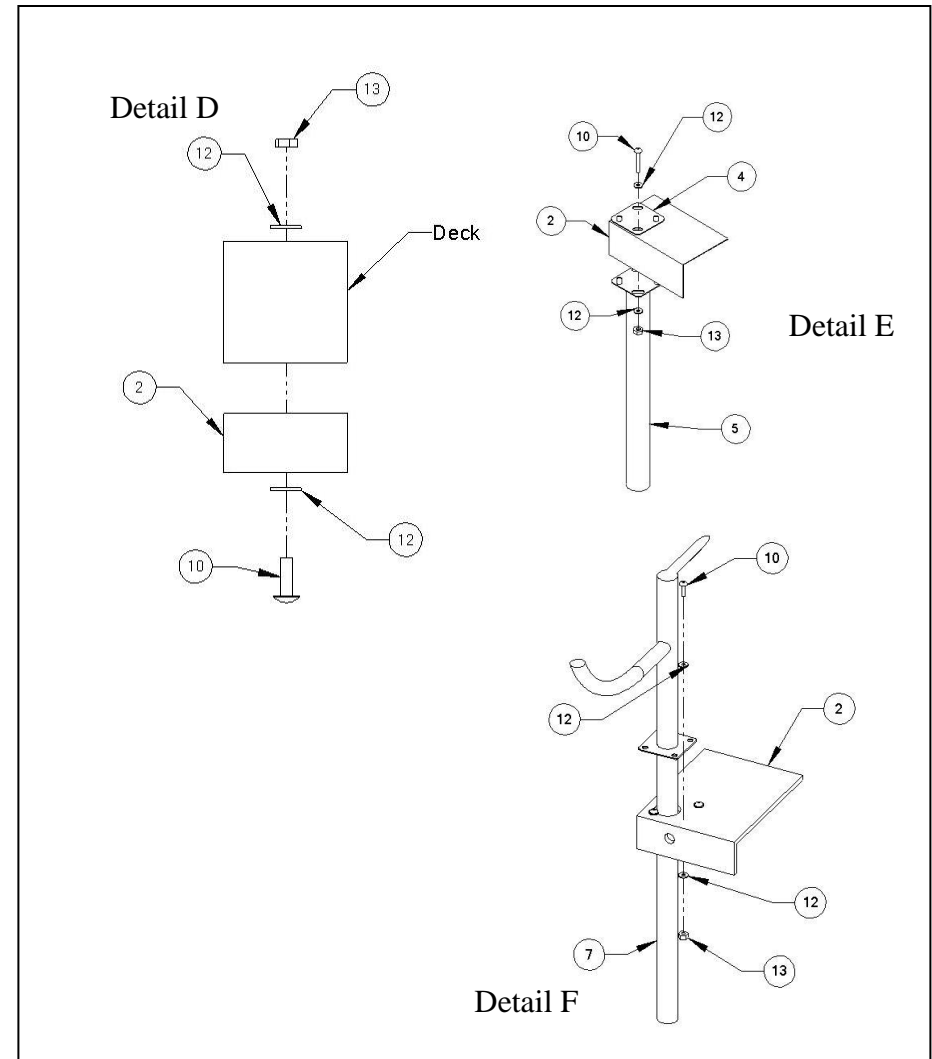

INSTALLATION STEPS CONTINUED

__8) **Install the Transfer Station Step:** To complete this step you will need the Transfer Station step (3), two Transfer Point Inside Legs (6), three 3/8" x 1" Button Head Bolts (10), two 3/8" x 1 1/4" Button Head Bolts (11), ten 3/8" Flat Washers, and five 3/8" Locknuts. First install the Transfer Point Inside Legs to the Transfer Station step. Using a 3/8" x 1 1/4" Button Head bolt with a 3/8" Flat Washer on each insert them through the Transfer Station Step. Place the flat side of the Transfer Point Inside Leg against the Transfer Station step and secure them with a 3/8" Flat Washer and a 3/8" Locknut. (See detail G) Place the Transfer Point Inside legs into their footing holes, then you need to place one 3/8" Flat Washer onto each of the three 3/8" x 1" Button Head Bolts, insert this assembly through the top of the Transfer Station Step and into the factory punched hole in the Transfer Station Platform. Secure the Transfer Station Step to the transfer Station Platform with a 3/8" Flat Washer and a 3/8" Locknut. (See detail H) Level the Transfer Station Platform and Transfer Station Step before you tighten the bolts.

__9) Once the entire playground has been installed and you have verified that the entire playground is level you can **add the concrete to the footing holes**. Be sure to use concrete with a minimum 2,500 psi and mix the concrete per the manufacturer's directions before you pour it into the footing hole. Once the footing has been filled with concrete you should rope of the area for a minimum of 48 hours to allow the concrete set properly.

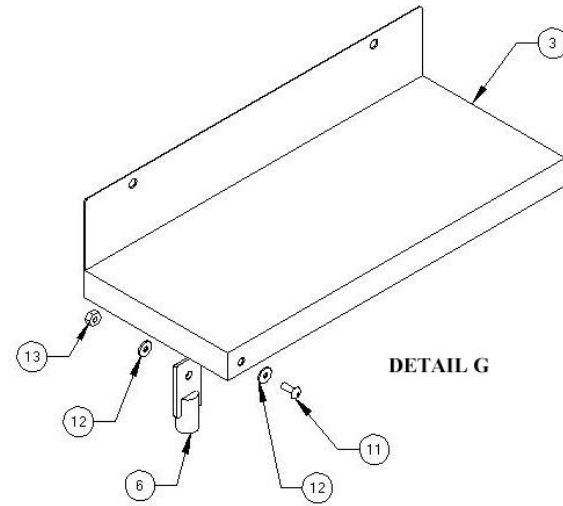

__10) **Once the concrete has set**, back fill dirt over the footing holes; inspect the area and components for tools, hazardous debris and sharp edges. Verify all components are installed and all hardware is tight and then install the safety surfacing.

__11) Inspect **the components**: for sharp edges and if necessary file them down and apply touch up paint.

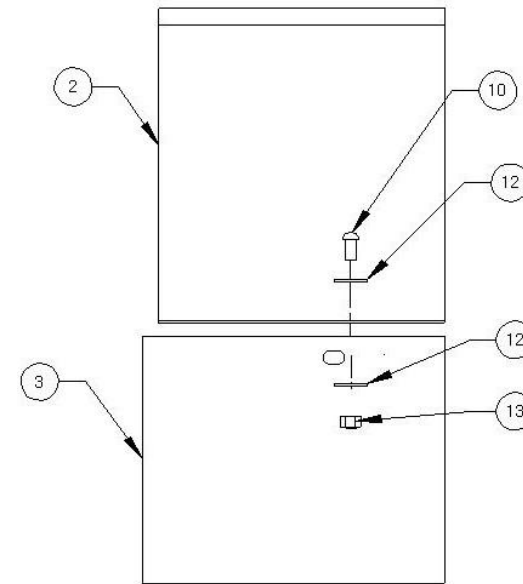

INSTALLATION DETAILS

- Recommended crew (Adult): 2
- Installation time: **1 hr (2 man hrs)**
- User age: **2-12**
- Use zone: **72 in. in front of climber**
72 in to right and left of climber
- Weight: **90**

SURFACING: Use of safety surfacing in compliance with ASTM specification F1292 is required.

MAINTENANCE:

- As the owner of the playground you are responsible for maintenance of the equipment and play area. A maintenance schedule must be developed and the equipment inspected frequently. A maintenance section that includes component specific maintenance requirements is included at the end of this manual.
- Be sure to inspect surfacing for foreign objects that could cause injury and that sufficient surfacing is in place in accordance with ASTM and CPSC standards.



PARTS LIST

ID	PART #	DESCRIPTION	QTY
1	913-443	Corkscrew 3' deck	1
2	913-402	Four-Hole Attachment Bracket	2
3	905-208	Attachment Bracket Gasket	2
4	905-526	Self-Tapping Screw	8
5	196-807	3/8"x3/8" Set Screw	2
6	126-703	3/8"x1" Button Head Bolt	2
7	316-601	3/8" Flat Washer	4
8	226-602	3/8" Lock Nut	2
9	116-538	5/16"x1 3/4" Button Head Bolt	1
10	216-512	5/16"x1" Button Head Nut	1
11	326-501	5/16" Lock Washer	1
12	923-214	Arch Wall	1

NOTE: Keep a copy of these instructions on file to assist you with maintenance and replacement parts.

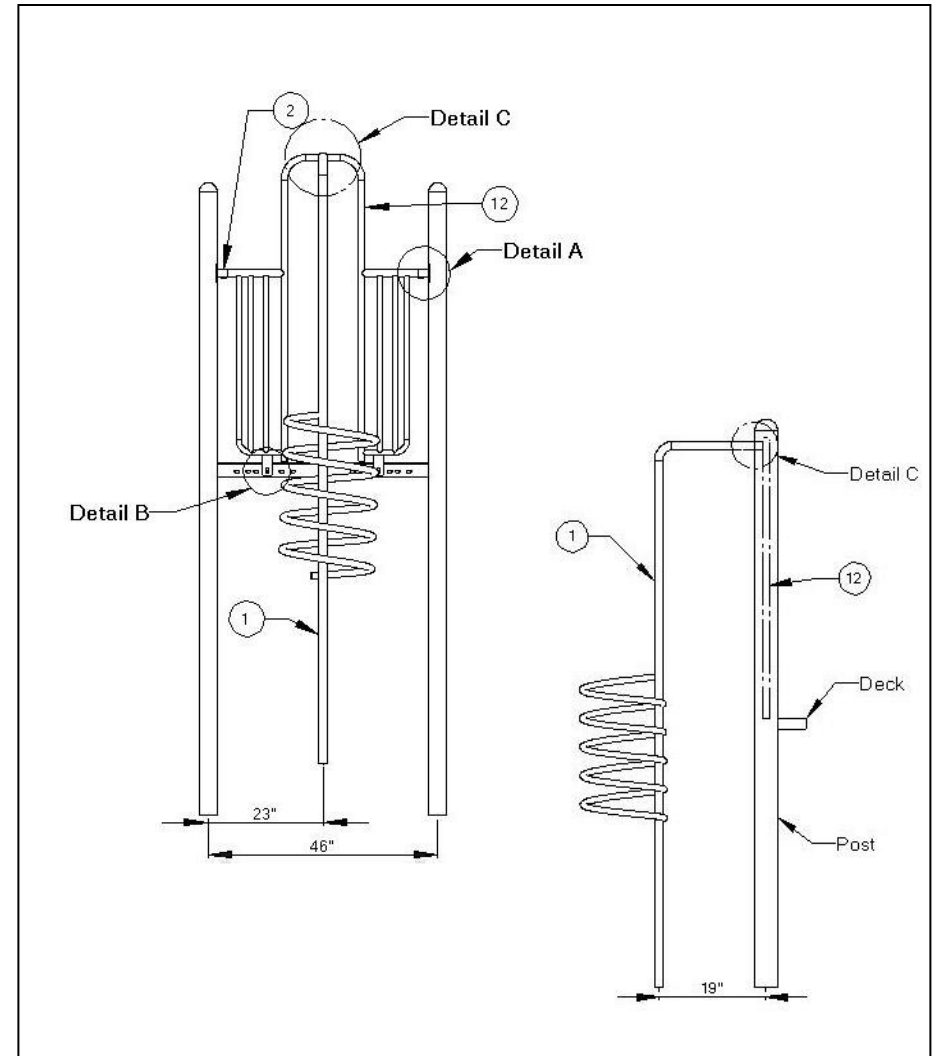

FOOTING INFORMATION

- Total footing depth is 24" less the height of the surfacing plus the height of the blocking material. If you were using 12" of surfacing the footing hole would need to be 12" plus the height of the blocking material (refer to the cutaway view to the right). Hole is 19" out from the post at the center of the deck edge (refer to the side view on page 2)
- If the Play structure is installed on an unlevel grade you must adjust the footing depth to accommodate the grade. For instance, if the grade for this component is 1" higher than the surface grade of the main playground post you must dig your footing hole 1" deeper.
- You must place the bottom of the post on a suitable flat blocking material to prevent it from sinking further into the soil. We recommend you use a brick, block of wood or several inches of gravel. The footing depth does not include this blocking material since materials used often vary.
- It is the owner/installers responsibility to check local building codes and to comply with those codes. All footing depths listed here are recommendations and local soil types and frost lines may require a deeper and/or wider footing depth. If that's the case you must add more blocking material to accommodate the deeper footing, as the post length will still only be installed at the depth listed in this instruction manual.
- Assemble the entire unit before adding the concrete unless instructed to do so in the individual component instruction sections.

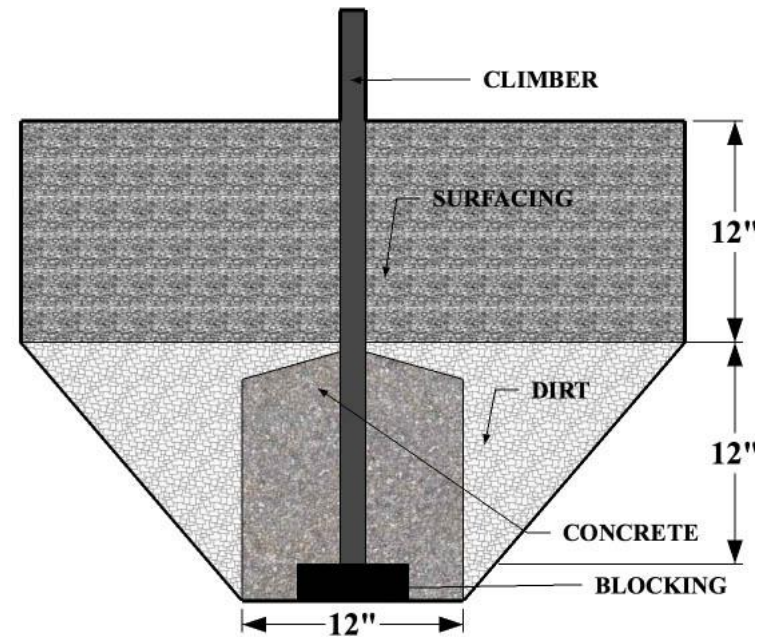

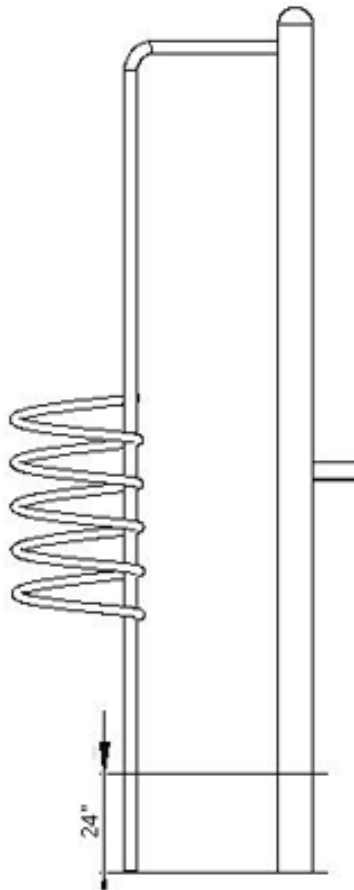

**922-120-3
3' CORKSCREW
CLIMBER**

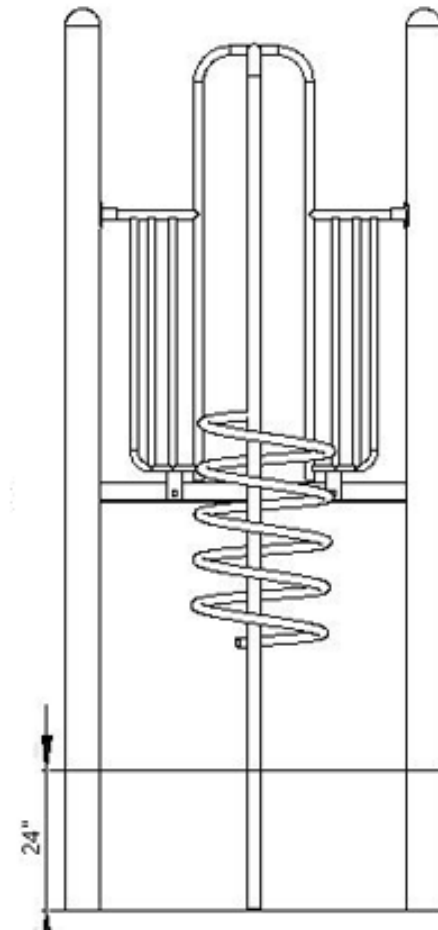



SPECIFICATIONS

- Paint – Electrostatically applied & oven cured powder coat
- Hardware – Stainless steel & tamper resistant
- Tube – FloCoat® Galvanized 1 3/8” OD and 1” OD.
- Attachment Bracket – Powder coated cast aluminum
- Corkscrew Climber–1 7/8” O.D. tube with 1 3/8 O.D. rolled tube welded to 1 7/8” tube
- Arch Wall-1 7/8”, 1 3/8”, and 1” O.D. tube MIG welded together

INSTALLATION TIPS & TROUBLE SHOOTING

- SportsPlay Equipment Inc. recommends pre-drilling the holes in the post when attaching a four-hole bracket with a number #7 drill bit. This will make the attachment of the four-hole bracket with the self-tapping screws easier and it will prevent damage to the screw head during installation.
- Apply loctite to all bolts during assembly prior to completely tightening them.
- Stainless Steel hardware can occasionally be difficult to use particularly if you need to take them out to make an adjustment. It is recommended that you add a drop of oil to bolts that may have to be removed before you install them.
- Do not tighten bolts all the way until the unit is completely assembled and all components are square and level.
- Identify and separate all parts by referencing the detail drawings and the parts list.
- As you unpack and separate the components use the cardboard sheets that were used for packing and shipping to prevent damage to the components. This is particularly true all Powder Coated and Thermoplastic coated components, by setting the components on top of the cardboard.

BEFORE YOU BEGIN

In addition to the components on the packing list you will need a shovel or post hole digger, cement, drill, and a level.

INSTALLATION STEPS

__1) **Review all instructions before beginning**

__2) **Unpack, organize and identify, all components:** Be sure to place all painted components on a protective surface (cardboard, cloth, etc...) to prevent damage.

__3) **Locate placement of Corkscrew Climber:** See top down view of your instruction booklet

__4) **Install Arch Wall:** Make sure that the attachment stub is facing away from the deck you are installing the Corkscrew Climber on. You will need the Arch Wall (12) two Four-Hole Attachment Brackets (2), two Attachment Bracket Gaskets (3), eight Self-Tapping Screws (4), two 3/8" x 3/8" Set Screws (5) two 3/8" x 1" Button Head Bolts (6), four 3/8" Flat washers (7) and two 3/8" Lock Nuts (8). First you will need to place the two Four-Hole Brackets on the Arch Wall. (See detail A) Using the 3/8" x 1" Button Head Bolts with a flat washer installed, place it through the Arch Wall and into the correct factory punched hole in the deck you are installing it to. Secure it with a 3/8" Flat Washer and 3/8" Locknut on the underside of deck, do not completely tighten locknut at this time. (See detail B)

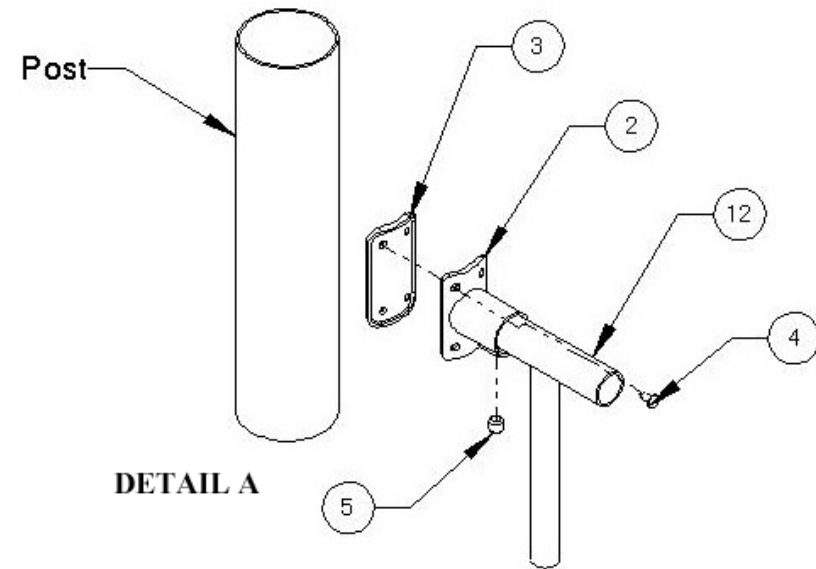

INSTALLATION STEPS CONTINUED

__5) **Connect four hole brackets to posts:** Now you need to install the Four Hole Brackets to the posts. The top of the barrier, NOT THE ARCH, should be 38" from the surface of the deck to the top of the barrier. Once you have the top of the barrier at the correct height tighten the two 3/8" x 1" Button Head bolts (6). The Four-Hole Brackets get installed with the Self-Tapping Screws (4) and Attachment Bracket Gaskets (5) make sure that the hole for the 3/8x 3/8" set screw is pointing down. **TIP: It's easier to install the self-tapping screws if you pre drill the holes in the post with a #7 drill bit by marking the hole locations with a dry erase marker after you have put the guard wall into position.** Install the Self-Tapping Screws into the holes you have drilled in the posts with the Attachment Bracket Gasket between the post and Four Hole Attachment Bracket. (See detail B)

__6) **Secure the Arch Wall to the Attachment Bracket:** Install and tighten the 3/8" x 3/8" Set Screw (5) in the Four -Hole Bracket. (See detail B)

__7) **Dig footing hole:** Referencing the footing cutaway drawings on page 3, the footing layout and elevation views on page 4 of this components instruction set along with the main footing diagram on page 5 of the installation guide, mark and dig the footings as instructed for the corkscrew Climber (1). (Footing depth is 24" less the amount of surfacing used plus the thickness of the blocking material).

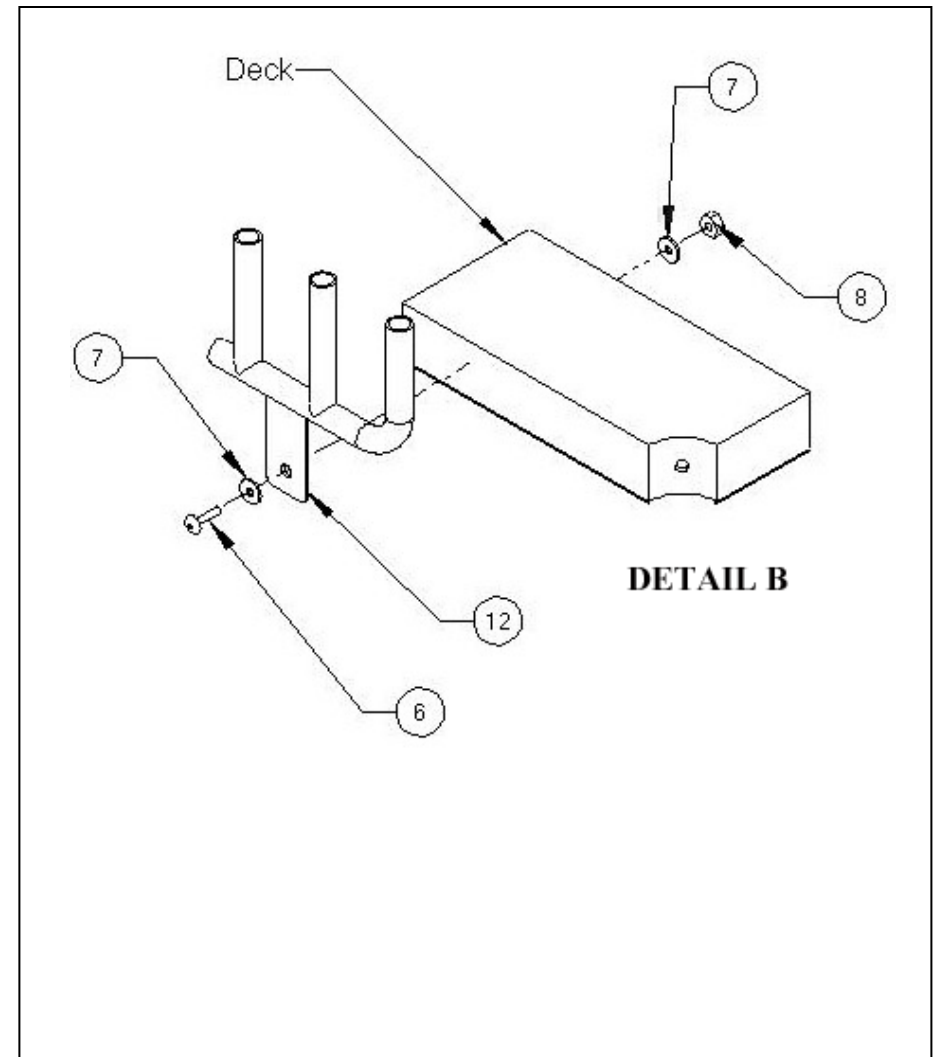

INSTALLATION STEPS CONTINUED

__8) **Install the Corkscrew climber:** Place the Corkscrew Climber over the stub on the Arch Wall and secure it with the 5/16" x 1 3/4" Button Head Bolt (9), 5/16" Button Head Nut (10), and 5/16" Lock Washer (11). (See detail C)

__9) Once the entire playground has been installed and you have verified that the entire playground is level you can **add the concrete to the footing holes**. Be sure to use concrete with a minimum 2,500 psi and mix the concrete per the manufacturer's directions before you pour it into the footing hole. Once the footing has been filled with concrete you should rope of the area for a minimum of 48 hours to allow the concrete set properly.

__10) **Once the concrete has set**, back fill dirt over the footing holes; inspect the area and components for tools, hazardous debris, and sharp edges. Verify all components are installed and all hardware is tight and then install the safety surfacing.

__11) **Inspect the components** for sharp edges and if necessary file them down and apply touch up paint.

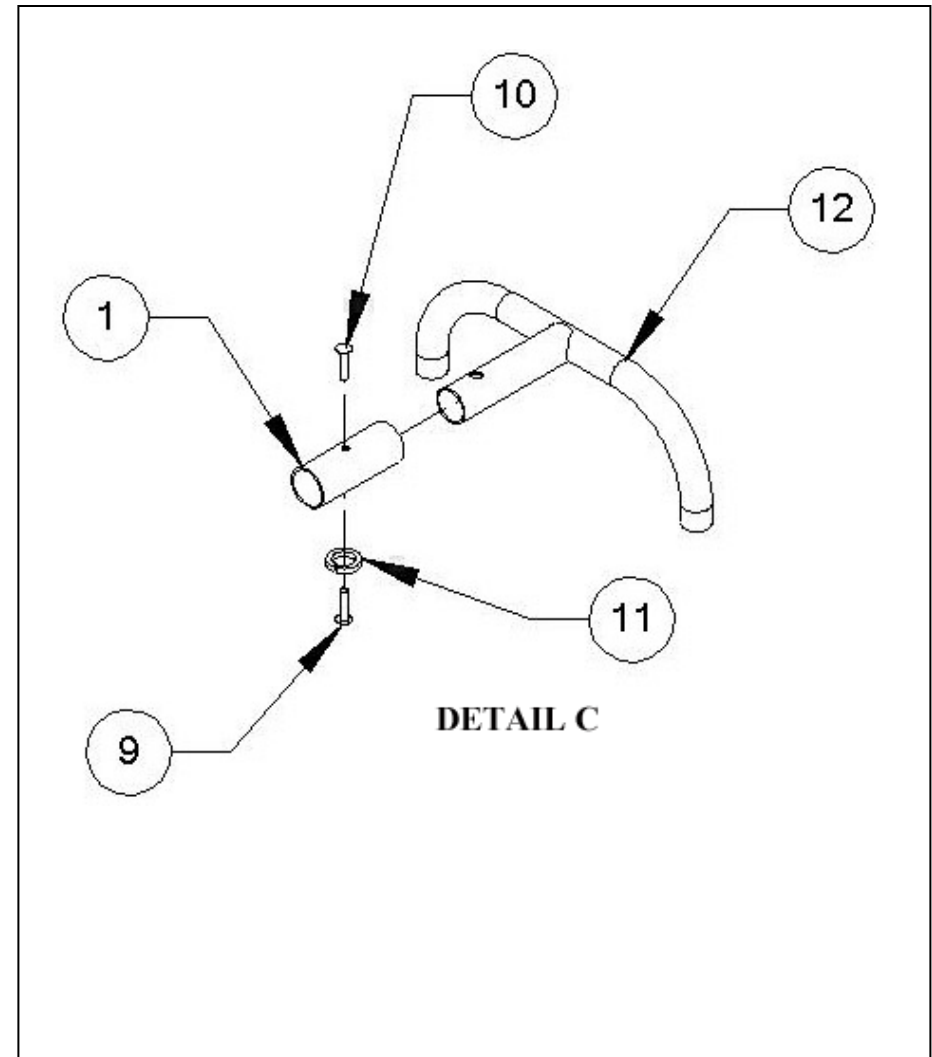

INSTALLATION DETAILS

- Recommended crew: 2
- Installation time: 2 Hours (4 man hours)
- User age: 2-12 Years
- Use zone: 6' on all sides
- Weight: 3' Slide 902-213 – 78 lbs.

SURFACING: Use of safety surfacing in compliance with the current ASTM specification F1292 is required.

MAINTENANCE:

- As the owner of the playground you are responsible for maintenance of the equipment and play area. A maintenance schedule must be developed and the equipment inspected frequently. A maintenance section that includes component specific maintenance requirements is included at the end of this manual.
- Be sure to inspect surfacing for foreign objects that could cause injury and that sufficient surfacing is in place in accordance with ASTM (www.astm.org) and CPSC (www.cpsc.gov) standards.

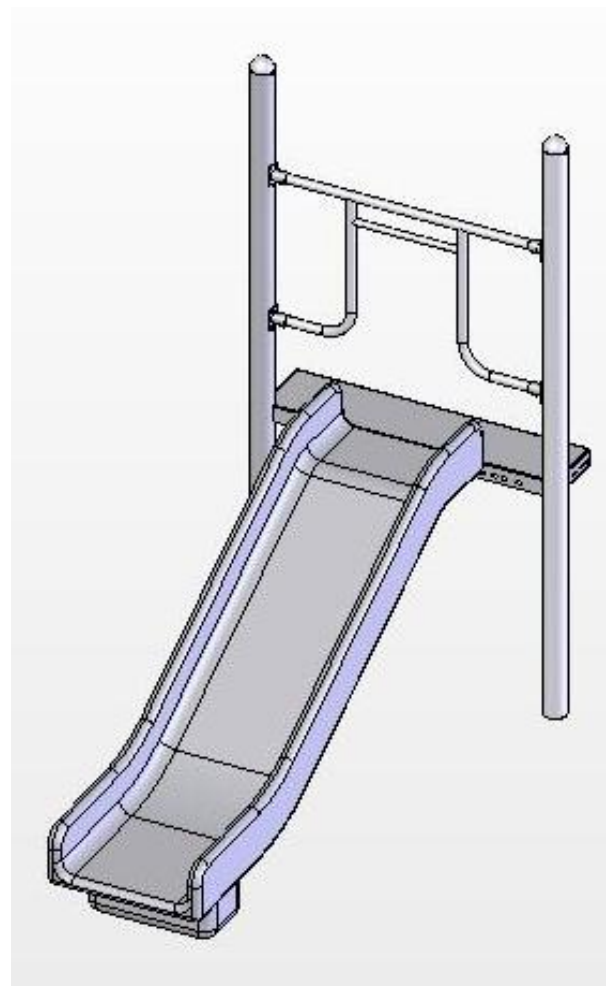

PARTS LIST

ID	PART #	DESCRIPTION	QTY
1	3' 435-600	Double Wall Slide	1
2	923-200	Slide Guard	1
3	903-214	Slide Leg	2
4	913-402	Four Hole Attachment Bracket	4
5	905-208	Gasket for Attachment Bracket	4
6	905-526	1/4" Self Tapping Pinned Screw	16
7	126-706	3/8 x 1 3/4 Button Head Bolt	2
8	316-601	3/8 Washer	6
9	126-702	3/8 x 3/4 Button Head Bolt	4
10	196-807	3/8 x 3/8 Socket Set Screw	4

NOTE: Keep a copy of these instructions on file to assist you with maintenance and replacement parts

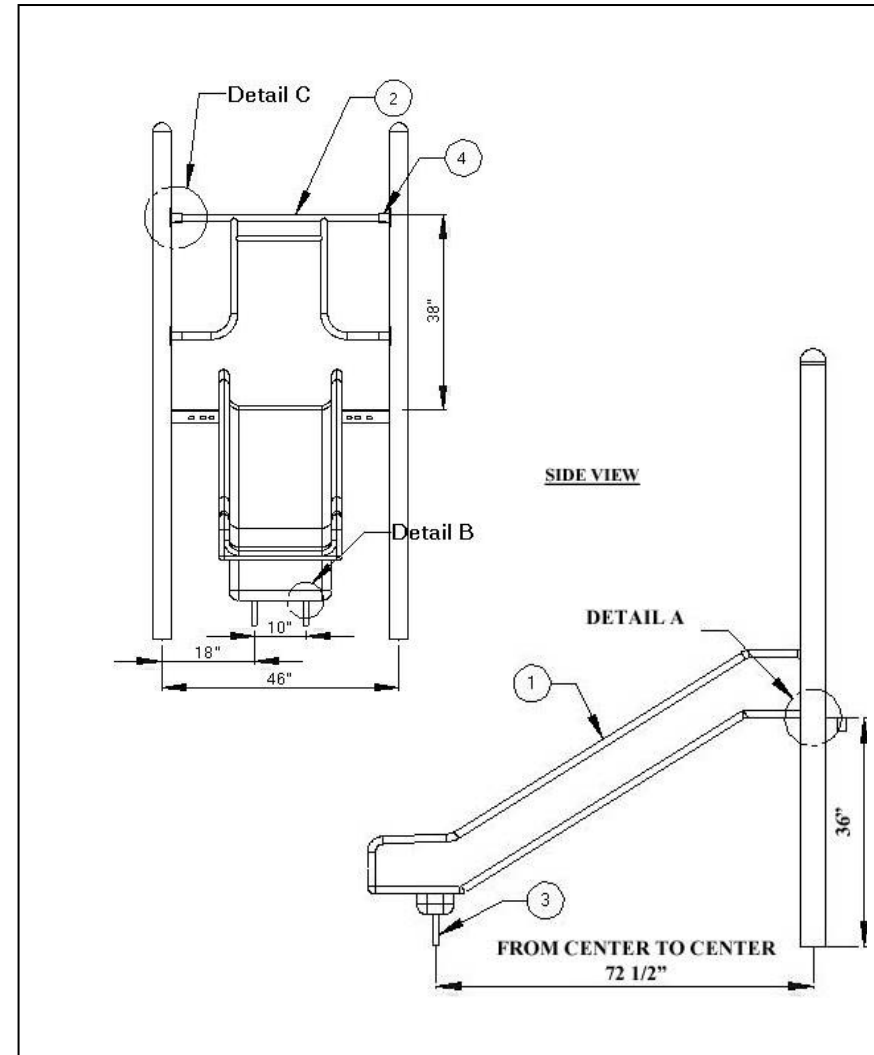

FOOTING INFORMATION

- You must place the bottom of the support post or slide leg on a suitable flat blocking material to prevent it from sinking further into the soil. We recommend you use a brick, block of wood or several inches of gravel. The footing depth does not include this blocking material since materials used often vary.
- Total footing depth is 24" less the height of the surfacing plus the height of the blocking material. If you were using 12" of surfacing the footing hole would need to be 12" plus the height of the blocking material (refer to both the side and front cutaway views to the right).
- If the Play structure is installed on an unlevel grade you must adjust the footing depth to accommodate the grade. For instance, if the grade for this component is 1" higher than the surface grade of the main playground post you must dig your footing hole 1" deeper.
- It is the owner/installers responsibility to check local building codes and to comply with those codes. All footing depths listed here are recommendations and local soil types and frost lines may require a deeper and/or wider footing depth. If that's the case you must add more blocking material to accommodate the deeper footing, as the post length will still only be installed at the depth listed in this instruction manual.
- Assemble the entire unit before adding the concrete unless instructed to do so in the individual component instruction sections.

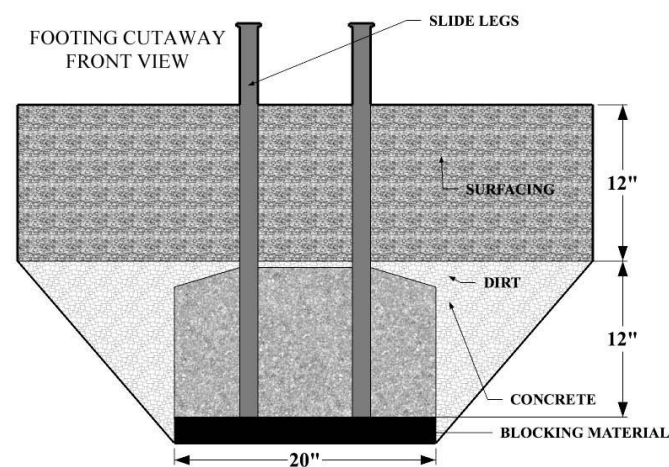
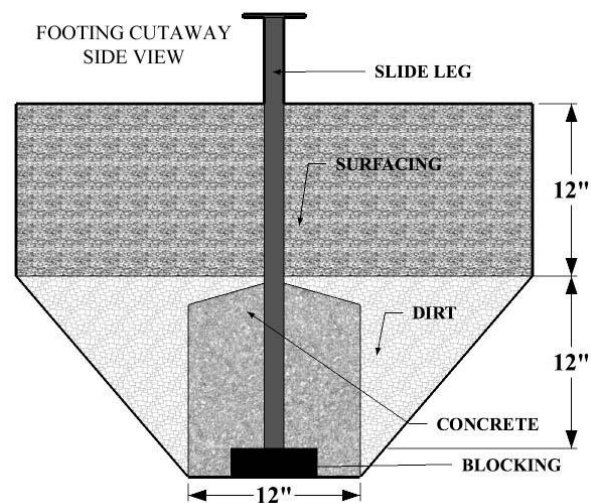

ELEVATION AND FOOTING
LAYOUT

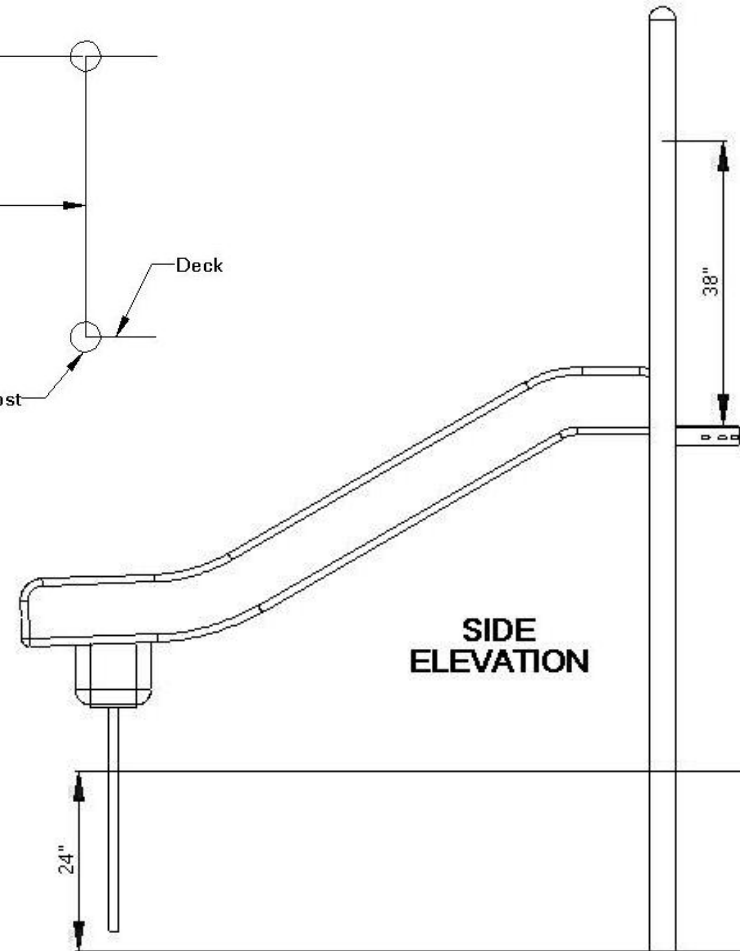
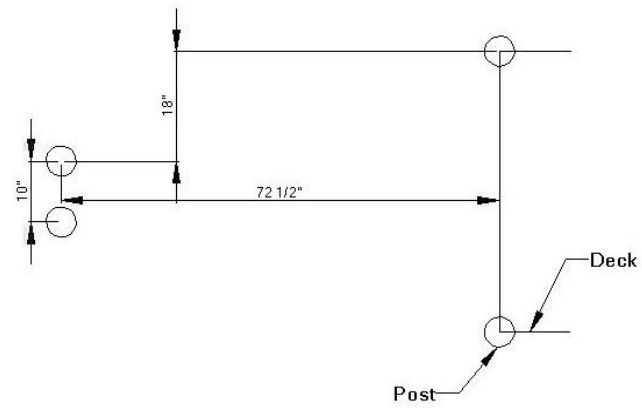
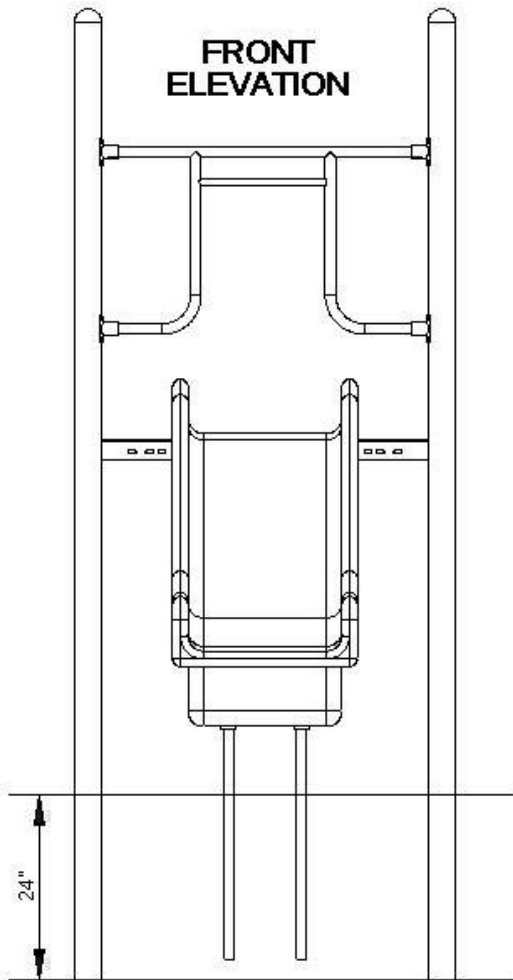



922-127-3 (3') DOUBLE WALL STRAIGHT SLIDE INSTALLATION INSTRUCTION

SPECIFICATIONS

- Slide – 3/8” walled rotationally molded LLDPE
- Paint – Electrostatically applied & oven cured powdercoat
- Hardware – Stainless steel & tamper resistant
- Tube – FloCoat® Galvanized 1 3/8” OD and 1” OD.
- Attachment Bracket – Powder coated cast aluminum

SPECIAL SAFETY COMPLIANCE NOTES

- ASTM F1487 8.5.5.2 The runout slope of slide exit region must be between 0 and -4 degrees.
- ASTM F 1487 8.5.5.3 For slides with an elevation of no greater than 48 in., the height of the exit region shall be no greater than 11 in. above the protective surfacing. For slides with an elevation greater than 48 in., the height of the exit region shall be between 7 in. and 15 in. above the protective surfacing

INSTALLATION TIPS & TROUBLE SHOOTING

- SportsPlay Equipment Inc. recommends pre-drilling the holes in the post when attaching a four-hole bracket with a number #7 drill bit. This will make the attachment of the four-hole bracket with the self-tapping screws easier and it will prevent damage to the screw head during installation.
- Apply locktite to all bolts during assembly prior to completely tightening them.
- Stainless Steel hardware can occasionally be difficult to use particularly if you need to take it out to make an adjustment. It is recommended that you add a drop of oil to bolts that may have to be removed before you install it.
- Do not tighten bolts all the way until the unit is completely assembled and all components are square and level.
- Identify and separate all parts by referencing the detail drawings and the parts list.
- As you unpack and separate the components, use the cardboard sheets that were used for packing and shipping to prevent damage to the components. This is particularly true for all Powder Coated and Thermoplastic coated components, by setting the components on top of the cardboard.

BEFORE YOU BEGIN

In addition to the components on the packing list, you will need concrete, shovel, post-hole digger, tape measure, ground marking (for marking the footing location), drill, hex wrenches and a dry erase marker.

INSTALLATION STEPS

__1. Review all instructions before beginning.

__2. Unpack, organize and identify all components. Be sure to place all painted components on a protective surface (cardboard, cloth, etc...) to prevent damage.

__3. Dig footing holes. Referencing the footing cutaway drawings on page 3, the footing layout and elevation views on page 4 of this components instruction set along with the main footing diagram on page 5 of the installation guide, mark and dig the footings as instructed for the slide legs. (Footing depth is 24" less the amount of surfacing used plus the thickness of the blocking material). SportsPlay recommends setting the slide up to the deck and using the slide to mark the position of the slide legs to establish the location of the required footing.

__4. Attach slide legs (#3) to the bottom of the slide by inserting a 3/8 x 3/4 bolt (#9) and 3/8 washer (#8) through the plate on the slide leg (#3) and into the factory installed nut on the underneath the exit end of the slide (Detail B). Once all bolts are in place you can tighten them.

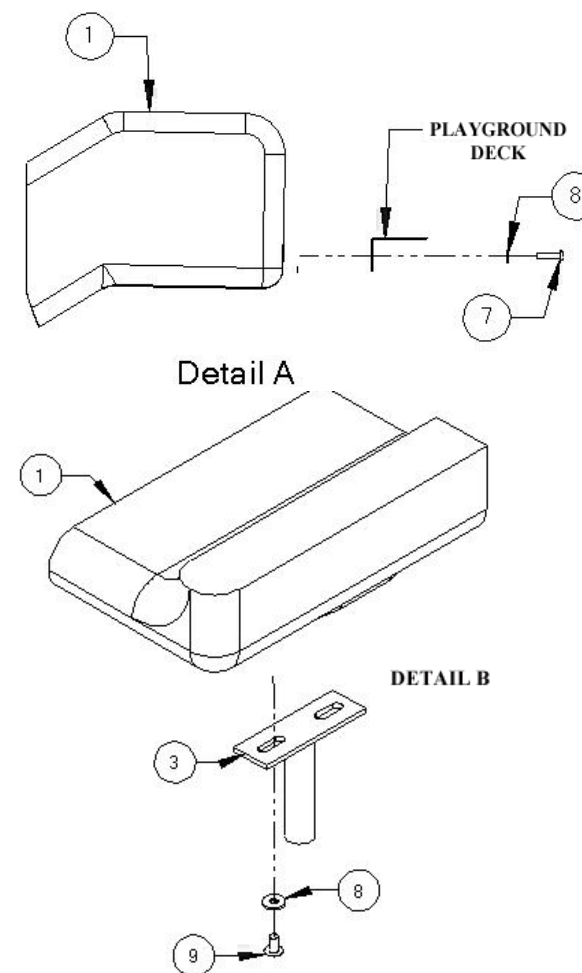

INSTALLATION STEPS CONTINUED

__5. With help, **place the slide legs into the footing holes** and attach the slide to the playground deck.

__6. Using the 3/8 x 1 3/4 bolts (#7) and 3/8 washers (#8) **attach the slide to the deck** by inserting the bolts and washers through the holes in the deck and into the factory installed nuts at the entrance to the slide (Detail A on page 6).

__7. **Measure up the playground post from the deck 38"** and mark that location on both of the playground posts. This mark represents the attachment point for the top of the slide guard (reference the front view drawing on page 2).

__8. **Slide all four of the four-hole attachment brackets on to the ends of the slide guard** (ensure the hole for the set screw on the bracket is facing down). After you have put the brackets onto the slide guard and attached the gaskets (#5) put the slide guard in place between the posts by lining up the top of the slide guard with the mark you made on the post in step 7. **Attach the slide guard to the posts** by screwing the self-tapping screws (#6) through the four-hole brackets and gaskets and into the playground post using the Torx bit and drill (Detail C). Repeat step on the remaining three brackets.

TIP: It's easier to install the self tapping screws if you pre drill the holes in the post with a #7 drill bit by marking the hole locations with a dry erase marker after you have put the guard wall into position.

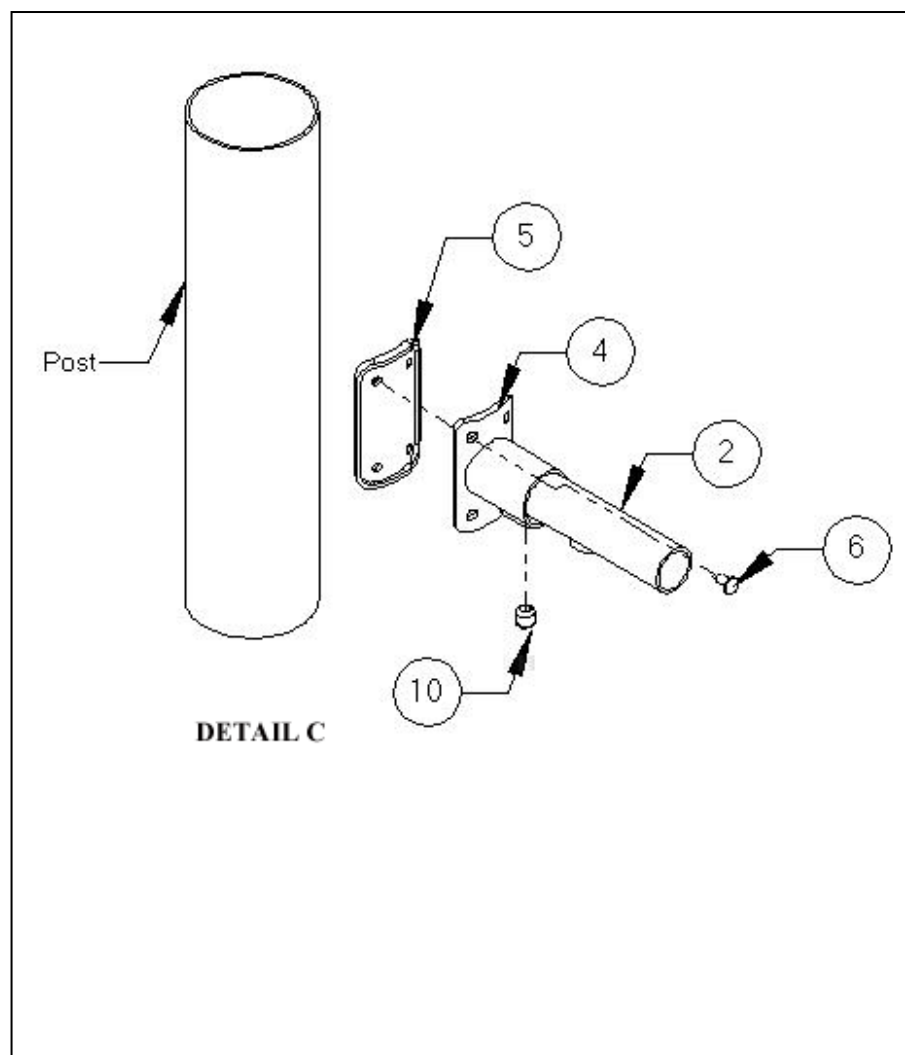



INSTALLATION INSTRUCTIONS CONTINUED

__9. **Insert the 3/8 x 3/8 socket set screws (#10)** into the threaded hole on the bottom side of the four-hole attachment brackets (#4) and tighten (Detail C on page 7).

__10. **Level and square the slide** making sure to keep 11" of spacing from the slide bed to the top of the safety surfacing.

__11. Once slide is in position and you have verified its square and level you may **tighten the bolts connecting the slide to the deck.**

__12. **Inspect the components** for sharp edges and if necessary file them down and apply touch up paint.

__13. Once the entire playground has been installed and you have verified that the entire playground is level you can **add the concrete to the footing holes.** Be sure to use concrete with a minimum 2,500 psi and mix the concrete per the manufacturers directions before you pour it into the footing hole. Once the footing has been filled with concrete you should rope of the area for a minimum of 48 hours to allow the concrete set properly.

__14. **Once the concrete has set,** back fill dirt over the footing holes; inspect the area and components for tools, hazardous debris and sharp edges. Verify all components are installed and all hardware is tight and then install the safety surfacing.

__15. **Install labeling** as instructed in the appendix of the instruction manual.

INSTALLATION DETAILS

- Recommended crew (Adult): 2
- Installation time:
- User age:
- Use zone:
- Weight: 912-807 – 76lbs.

SURFACING: Use of safety surfacing in compliance with ASTM specification F1292 is required.

MAINTENANCE:

- As the owner of the playground you are responsible for maintenance of the equipment and play area. A maintenance schedule must be developed and the equipment inspected frequently. A maintenance section that includes component specific maintenance requirements is included at the end of this manual.
- Be sure to inspect surfacing for foreign objects that could cause injury and that sufficient surfacing is in place in accordance with ASTM and CPSC standards.

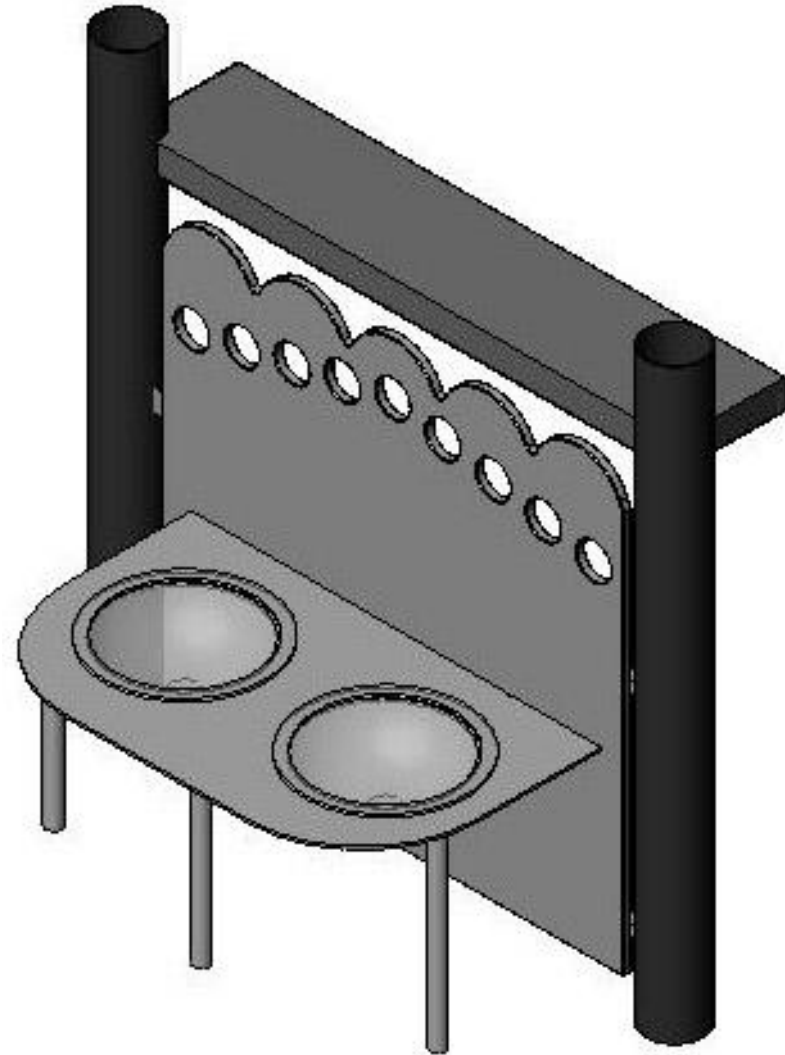

PARTS LIST

ID	PART #	DESCRIPTION	QTY
1	903-225	Sand & Water Panel	1
2	903-229	Bubble Basin	1
3	435-810	12" Acrylic Dome	2
4	903-816	1" Leg Support	3
5	913-417	Panel Attachment Bracket	4
6	905-208	Gasket for Attachment Bracket	4
7	905-526	Self Tapping Screws	16
8	905-803	Corner Bracket	3
9	316-501	5/16" Washers	10
10	116-529	5/16"x3/4" Button Head Bolt	10
11	216-512	5/16"x1" Button Head Nut	10
12	316-601	3/8" Flat Washer	32
13	126-701	3/8"x1 1/4" Button Head Bolt	19
14	236-601	3/8" T Nut	16
15	316-903	Rubber Washer	16
16	905-806	PVC Bushing 3/4"	2
17	905-807	PVC Cap 3/4"	2
18	905-808	Conduit Locknut 3/4"	2
19	905-809	O Ring Large	2

NOTE: Keep a copy of these instructions on file to assist you with maintenance and replacement parts.

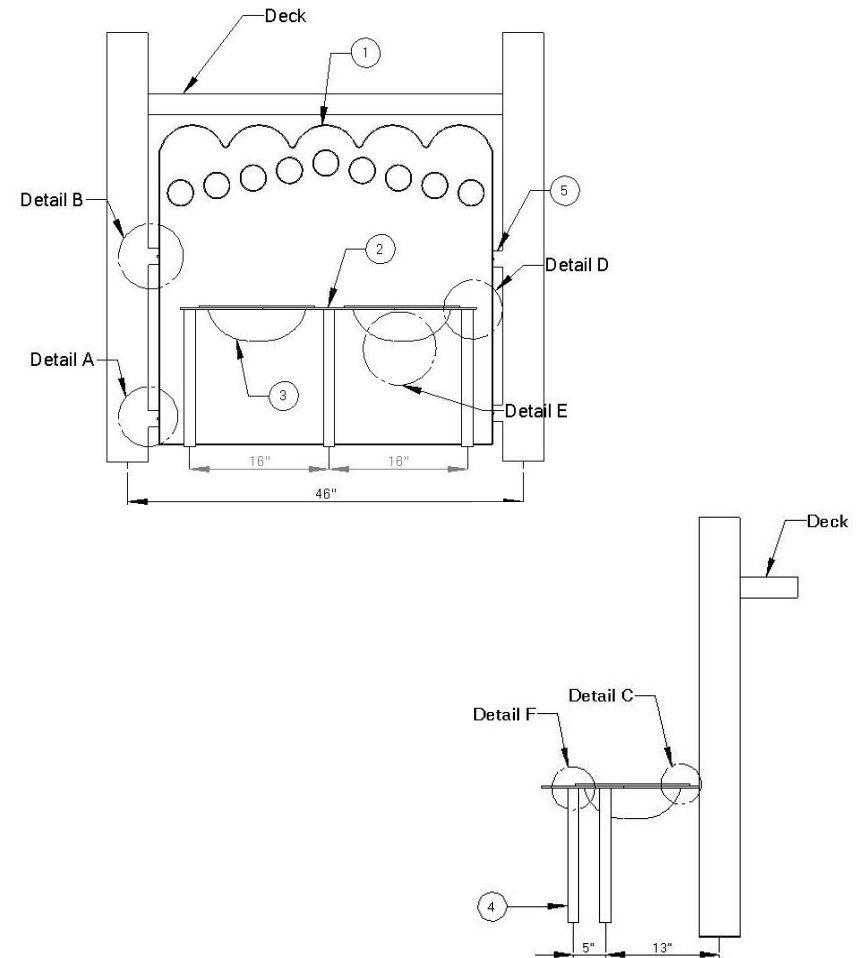



FOOTING INFORMATION

- Total footing depth is 24” less the height of the surfacing plus the height of the blocking material. If you are using 12” of surfacing the footing hole would need to be 12” plus the height of the blocking material.
- If the Play structure is installed on a unlevel grade you must adjust the footing depth to accommodate the grade. For instance, if the grade for this component is 1” higher than the surface grade of the main playground post you must dig your footing hole 1” deeper.
- You must place the bottom of the support post or slide leg on a suitable flat blocking material to prevent it from sinking further into the soil. We recommend you use a brick, block of wood or several inches of gravel. The footing depth does not include this blocking material since materials used often vary.
- It is the owner/installers responsibility to check local building codes and to comply with those codes. All footing depths listed here are recommendations and local soil types and frost lines may require a deeper and/or wider footing depth. If that’s the case you must add more blocking material to accommodate the deeper footing, as the post length will still only be installed at the depth listed in this instruction manual.
- Assemble the entire unit before adding the concrete unless instructed to do so in the individual component instruction sections.

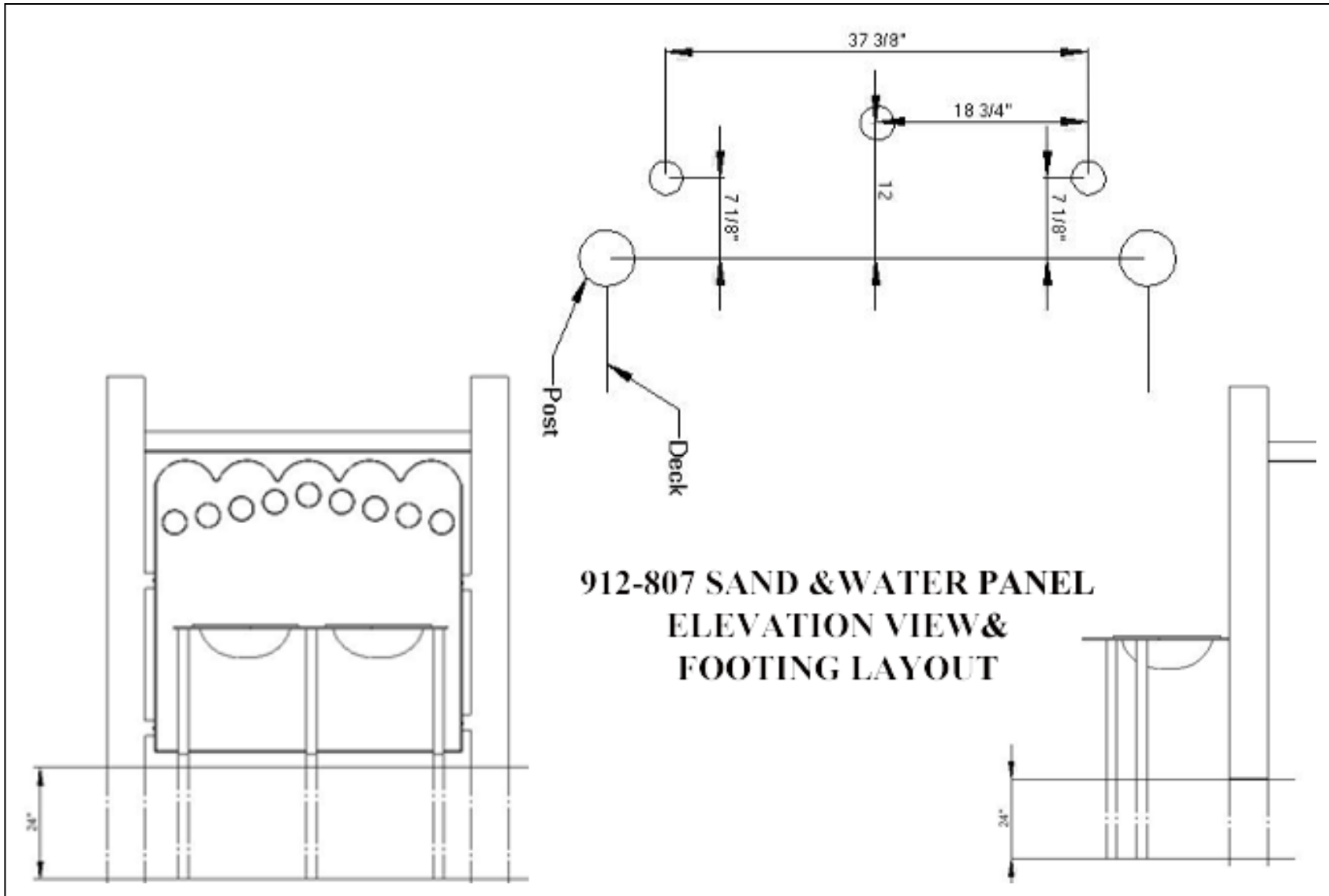



SPECIFICATIONS

- Panel- 3/4" HDPE UV stabilized plastic
- Hardware – Stainless steel & tamper resistant
- Attachment Bracket – Powder coated steel
- Bowls – Polycarbonate
- Drain – Mixed parts consisting of PVC, Rubber and steel

SPECIAL SAFETY & ASTM COMPLIANCE NOTES

- Must be installed below deck or on stand alone posts
- Gaps between the top of the panel and a deck must be less than 3" or greater than 9"
- Gaps between the post and the panel shall be 3" or less

INSTALLATION TIPS & TROUBLE SHOOTING

- SportsPlay Equipment Inc. recommends pre-drilling the holes in the post when attaching a four-hole bracket with a number #7 drill bit. This will make the attachment of the four-hole bracket with the self-tapping screws easier and it will prevent damage to the screw head during installation.
- Apply locktite to all bolts during assembly prior to completely tightening them.
- Stainless Steel hardware can occasionally be difficult to use particularly if you need to take them out to make an adjustment. It is recommended that you add a drop of oil to bolts that may have to be removed before you install them.
- Do not tighten bolts all the way until the unit is completely assembled and all components are square and level.
- Identify and separate all parts by referencing the detail drawings and the parts list.
- As you unpack and separate the components, use the cardboard sheets that were used for packing and shipping to prevent damage to the components. This is particularly true all Powder Coated and Thermoplastic coated components, by setting the components on top of the cardboard.

INSTALLATION STEPS

__1) You will need to assemble the panel first. To do this you will need the panel (1) and bubble basin (2), three Corner Brackets (8), six 5/16" Washers (9), six 5/16" x 3/4" Button Head Bolt (10), six 5/16" x 1" Button Head Nut (11), six 3/8" Flat Washer (12). First attach the 3 corner brackets to the bubble basin (see detail D). Then attach the bubble basin to the panel (also detail D).

__2) Install the assembled panel to the playground structure. To do this you will need four Panel Attachment Brackets (5), four Attachment Bracket Gaskets (6), sixteen Self Tapping Screws (7), three 3/8" x 1 1/4" Button Head Bolt (13), seven 3/8" Flat Washer (12), four 5/16" x 1" Button Head Nut (11). First you will need to locate the posts that the panel attaches to. (Refer to the overhead drawing in your instruction booklet)

CRITICAL MEASUREMENT IT IS EXTREMELY IMPORTANT THAT YOU MAINTAIN A 3" DISTANCE BETWEEN THE TOP OF THE PANEL AND THE NEAREST EDGE OF THE POSTS AND THE PANEL SHOULD BE LESS THAN OR EQUAL TO 3" OR GREATER THAN 9" FROM THE TOP OF THE PANEL TO THE BOTTOM OF THE DECK.

__3) Secure the panel attachment brackets to the posts. Using the self-tapping screws (7) with the attachment bracket gasket (6) between the post and the attachment bracket (5). It may be necessary to pre drill the holes for the self-tapping screws. (See detail A)

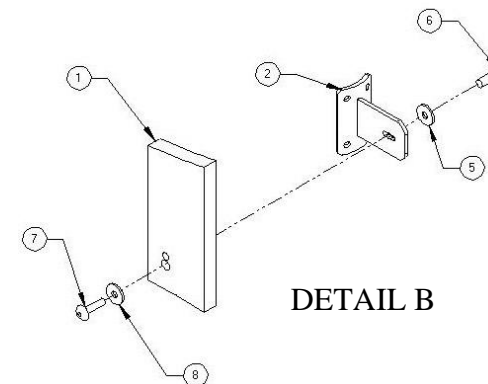
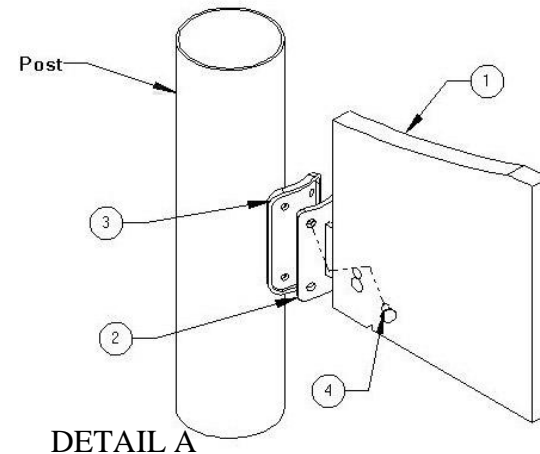

INSTALLATION STEPS CONTINUED

__4) Install panel to attachment brackets: Once you have all 4 of the panel attachment brackets installed. Locate the panel, with a helper lift the panel into place and mark the holes in the tab of the panel attachment bracket on the panel. Next you need to drill a 1/2” hole in the panel at the marks you made from the panel attachment brackets with the dry erase marker.(see detail B)

__5) Install support legs To complete this step you will need the three 1” Leg Supports (4), three 3/8” Flat Washer (12), three 3/8” x1 1/4” Button Head Bolt (13) Attach the support legs to the bubble basin (2) with the bolt and flat washer passing through the basin and into the support leg. (One end of the support leg will be threaded See detail F)

__6) Install the drain assembly: For this step you will need two 12” acrylic domes packed in a separate box, two PVC Bushings (16), Two PVC Caps (17), Two Conduit Locknuts (18), and two Large O Rings (19). Once you have located the parts you need insert the PVC bushing through the hole in the bottom of the dome with the O-ring installed on the bushing then place the bushing in the bubble. The O-ring will be on the inside of the bubble. Install the Conduit Locknut on the PVC Bushing. (Only tighten the locknut enough to prevent it from leaking) SEE DETAIL E

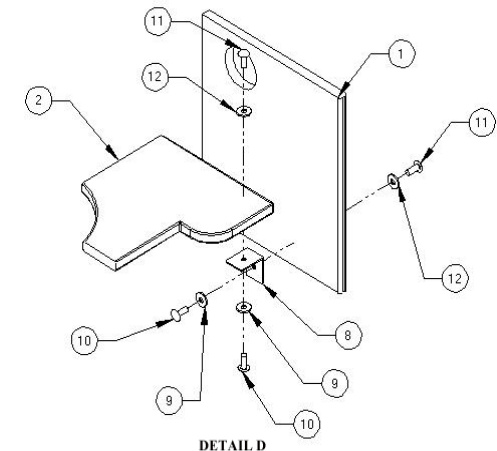
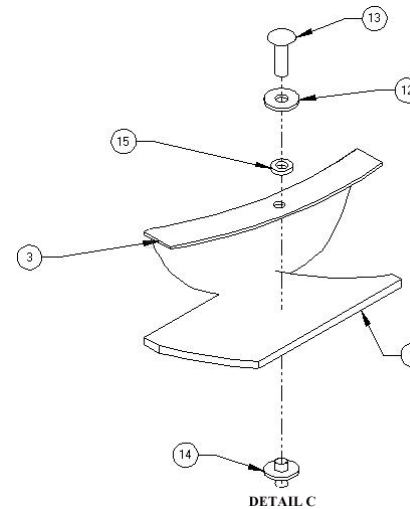

INSTALLATION STEPS CONTINUED

7) Install the Acrylic Domes in Bubble Basin To complete this step you will need the two 12" acrylic domes with the drain assemblies installed in the previous step. You will also need sixteen 3/8" Flat Washer (12), sixteen 3/8" x 1 1/4" Button Head Bolt (13), sixteen 3/8" T Nuts (14), and sixteen Rubber Washers (16). Place the acrylic domes into the bubble basin (drain facing the ground). Each bolt will need a 3/8 Flat Washer installed on it first then a rubber washer and placed into the factory drilled hole and secure it with the 3/8" T Nut on the bottom of the Bubble Basin (see detail C) The 3/8" T Nut must be installed with the flat side facing the ground. Do not use locktite on this step. (SEE DETAIL C)

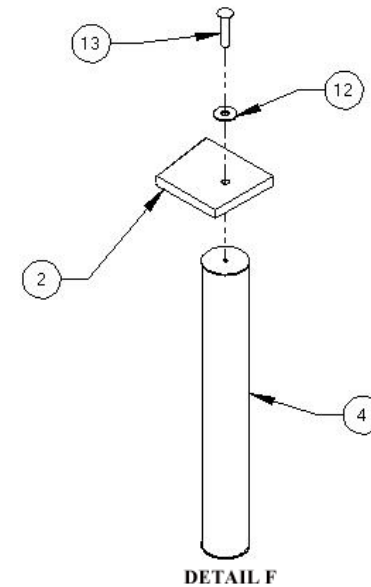

INSTALLATION DETAILS

- Recommended crew (Adult): 2
- Installation time: **1 Hour (2 man hrs)**
- User age: **2-12 Years**
- Use zone: **NA**
- Weight: **41**

SURFACING: Use of safety surfacing in compliance with ASTM specification F1292 is required.

MAINTENANCE:

- As the owner of the playground you are responsible for maintenance of the equipment and play area. A maintenance schedule must be developed and the equipment inspected frequently. A maintenance section that includes component specific maintenance requirements is included at the end of this manual.
- Be sure to inspect surfacing for foreign objects that could cause injury and that sufficient surfacing is in place in accordance with ASTM and CPSC standards.

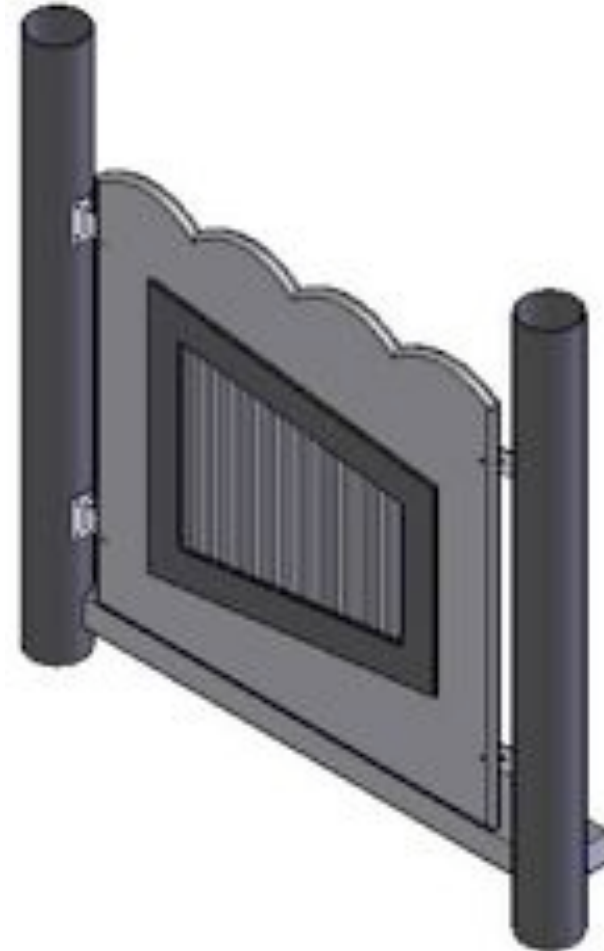

PARTS LIST

ID	PART #	DESCRIPTION	QTY
1	913-509	Music Panel	1
2	913-417	Panel Attachment Bracket	4
3	905-208	Gasket for Attachment Bracket	4
4	905-526	Self Tapping Screws	16
5	316-501	5/16" Flat Washer	4
6	116-529	5/16"x3/4" Button Head Bolt	4
7	216-512	5/16"x1" Button Head Bolt	4
8	316-601	3/8" Flat Washer	4

NOTE: Keep a copy of these instructions on file to assist you with maintenance and replacement parts.

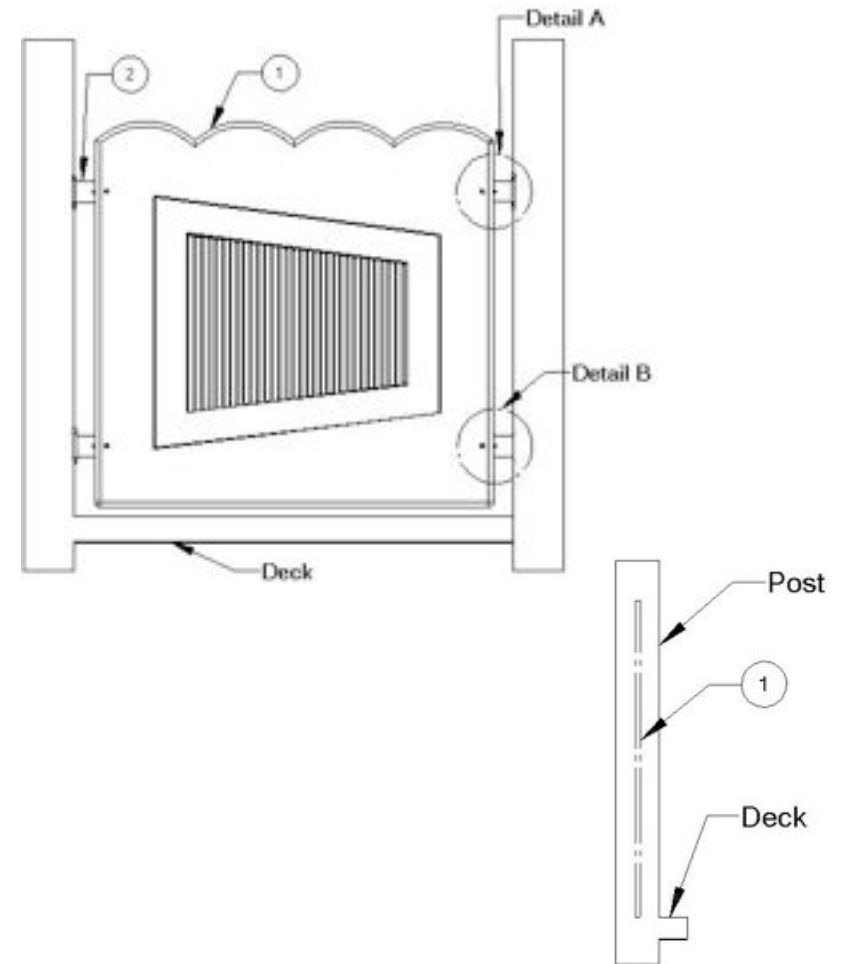



SPECIFICATIONS

- Panel- 3/4" HDPE UV stabilized plastic
- Hardware – Stainless steel & tamper resistant
- Attachment Bracket – Powder coated steel

SPECIAL SAFETY & ASTM COMPLIANCE NOTES

- CRITICAL MEASUREMENT IT IS EXTREMELY IMPORTANT THAT YOU MAINTAIN A MAXIMUM OF 3" DISTANCE BETWEEN THE TOP, BOTTOM, OR SIDES OF THE PANEL AND THE NEAREST EDGE OF THE DECK OR POSTS.

INSTALLATION TIPS & TROUBLE SHOOTING

- SportsPlay Equipment Inc. recommends pre-drilling the holes in the post when attaching a four-hole bracket with a number #7 drill bit. This will make the attachment of the four-hole bracket with the self-tapping screws easier and it will prevent damage to the screw head during installation.
- Apply locktite to all bolts during assembly prior to completely tightening them.
- Stainless Steel hardware can occasionally be difficult to use particularly if you need to take them out to make an adjustment. It is recommended that you add a drop of oil to bolts that may have to be removed before you install them.
- Do not tighten bolts all the way until the unit is completely assembled and all components are square and level.
- Identify and separate all parts by referencing the detail drawings and the parts list.
- As you unpack and separate the components, use the cardboard sheets that were used for packing and shipping to prevent damage to the components. This is particularly true all Powder Coated and Thermoplastic coated components, by setting the components on top of the cardboard.



BEFORE YOU BEGIN

In addition to the components on the packing list you will need a drill with a 1/2" drill bit and a dry erase marker ----.

INSTALLATION STEPS

- __1) Review all instructions before beginning**
- __2) Unpack, organize, and identify all components.** Be sure to place all painted components on a protective surface (cardboard, cloth, etc...) to prevent damage.
- __3) Locate placement of panel** Refer to the overhead drawing in your instruction booklet.

CRITICAL MEASUREMENT IT IS EXTREMILY IMPORTANT THAT YOU MAINTAIN A MAXIMUM OF 3" DISTANCE BETWEEN THE TOP, BOTTOM, OR SIDES OF THE PANEL AND THE NEAREST EDGE OF THE DECK OR POSTS.

INSTALLATION STEPS CONTINUED

4) Attach panel attachment brackets You will need the four panel attachment brackets (2), four attachment bracket gaskets (3), sixteen self tapping screws (4). Determine the proper placement for the panel attachment brackets. (This will vary with different deck heights and locations). You will need to mock up the panel and Attachment Brackets to determine this. Secure the panel attachment brackets to the posts using the self-taping screws with the attachment bracket gasket between the post and the attachment bracket. (SEE DETAIL A)

-TIP: It's easier to install the self-tapping screws if you pre drill the holes in the post with a #7 drill bit by marking the hole locations with a dry erase marker

5) Mark holes: Once you have all four of the panel attachment brackets installed, locate the panel. With help lift the panel into place and mark the holes in the tab of the panel attachment bracket on the panel. IT IS EXTREMELY IMPORTANT THAT YOU MAINTAIN A MAXIMUM OF 3" DISTANCE BETWEEN THE TOP, BOTTOM, OR SIDES OF THE PANEL AND THE NEAREST EDGE OF THE DECK OR POSTS.

6) Drill a 1/2" hole in the panel at the marks made from the panel attachment brackets

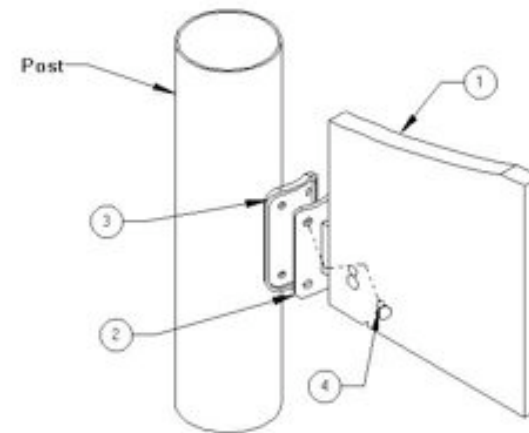

DETAIL A

INSTALLATION STEPS CONTINUED

__7) Install the panel Locate the four 5/16" flat washers (5), 5/ four 16x3/4" button head bolt (6), four 5/16x1" button head nuts (7), four 3/8" flat washers and locktite. Lift the panel up to the panel attachment brackets and secure it with the hardware listed in this step. (SEE DETAIL B) Tighten all hardware.

__8) Inspect the components for sharp edges and if necessary file them down and apply touch up paint.

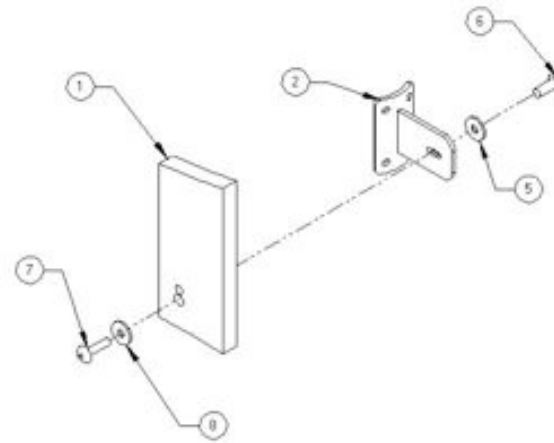

DETAIL B

INSTALLATION DETAILS

- Recommended crew (Adult): 2
- Installation time: **1 hr (2 man hrs)**
- User age: **2-12**
- Use zone: **NA**
- Weight: **92 lbs**

SURFACING: Use of safety surfacing in compliance with ASTM specification F1292 is required.

MAINTENANCE:

- As the owner of the playground you are responsible for maintenance of the equipment and play area. A maintenance schedule must be developed and the equipment inspected frequently. A maintenance section that includes component specific maintenance requirements is included at the end of this manual.
- Be sure to inspect surfacing for foreign objects that could cause injury and that sufficient surfacing is in place in accordance with ASTM and CPSC standards.

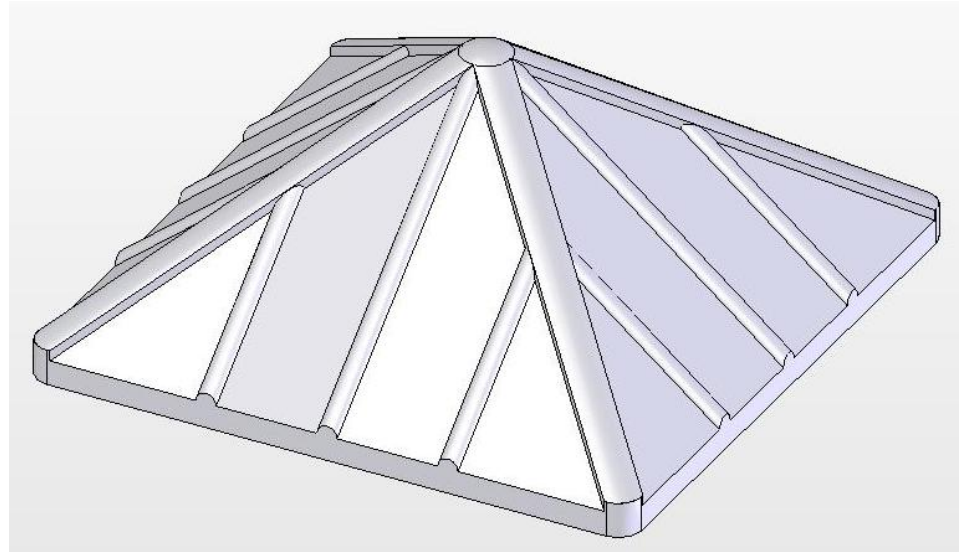



SPECIFICATIONS

- **Paint** – Electrostatically applied & oven cured powder coat
- **Hardware** – Stainless steel & tamper resistant
- **Tube** – FloCoat® Galvanized 1 3/8” O.D. and 1” O.D.
- **Pyramid Roof**-Roto-Molded Plastic.

SPECIAL SAFETY & ASTM COMPLIANCE NOTES

- (MUST INCLUDE SECTION IN STANDARD)

INSTALLATION TIPS & TROUBLE SHOOTING

- SportsPlay Equipment Inc. recommends pre-drilling the holes in the post when attaching a four-hole bracket with a number #7 drill bit. This will make the attachment of the four-hole bracket with the self-tapping screws easier and it will prevent damage to the screw head during installation.
- Apply locktite to all bolts during assembly prior to completely tightening them.
- Stainless Steel hardware can occasionally be difficult to use particularly if you need to take them out to make an adjustment. It is recommended that you add a drop of oil to bolts that may have to be removed before you install them.
- Do not tighten bolts all the way until the unit is completely assembled and all components are square and level.
- Identify and separate all parts by referencing the detail drawings and the parts list.
- As you unpack and separate the components, use the cardboard sheets that were used for packing and shipping to prevent damage to the components. This is particularly true all Powder Coated and Thermoplastic coated components, by setting the components on top of the cardboard.

BEFORE YOU BEGIN

In addition to the components on the packing list you will need a drill and 3/4" drill bit, tape measure, marker, and a ladder.

INSTALLATION STEPS

__1) Review all instructions before beginning:

__2) Unpack, organize, and identify all components: Be sure to place all painted components on a protective surface (cardboard, cloth, etc...) to prevent damage.

__3) Locate placement of the Pyramid Roof: See top down view of your instruction booklet.

__4) Temporarily set the Roof Brackets and Pyramid Roof in place: You will need to set each of the four Roof Brackets (2) on the posts that will support the Pyramid Roof. The rounded side of the Roof Bracket will face to the inside of the deck. *Do not permanently attach them at this time.* Now you can set the Pyramid Roof onto the Roof Brackets. (See detail A)

__5) Center the Pyramid Roof: Measure from each edge of the four Roof Brackets to the edge of the Pyramid Roof to center the Pyramid Roof over the deck. Mark the eight holes in the four Roof Brackets.

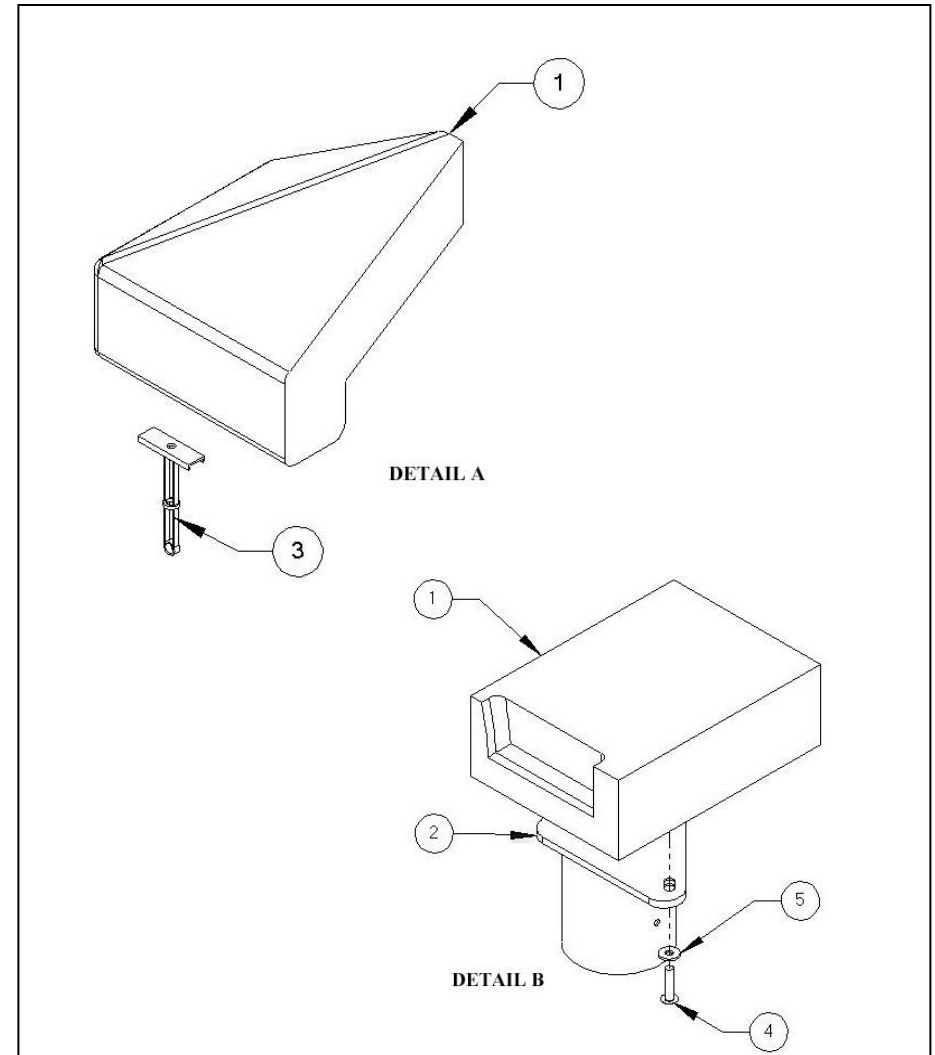

INSTALLATION STEPS CONTINUED

__6) **Drill holes into the Pyramid Roof:** Rotate the Pyramid Roof to allow access to the marks you made in the previous step. Drill each of the eight marks with the 3/4" drill bit. Install a Zip Toggler (3) into each of the holes. Now you can rotate the pyramid Roof back into position.

__7) **Attach the pyramid Roof to the Roof Brackets:** Now that you have the Pyramid Roof lined back up with the Roof Brackets. Install the 3/8" x 2" Button Head Bolt (4) with a 3/8" Flat Washer (5) in on it through the Roof Bracket and into the Pyramid Roof. *Do not tighten these until you have centered the roof with the deck.*

(See detail B)

__8) **Secure the Roof Brackets to the posts:** Now that you have everything attached and centered over the deck, you can install a Self Tapping Screw (6) through the Roof Bracket and into the post. Do this for each of the Roof Brackets. (See detail C)

__9) **Inspect the components:** for sharp edges and if necessary file them down and apply touch up paint.

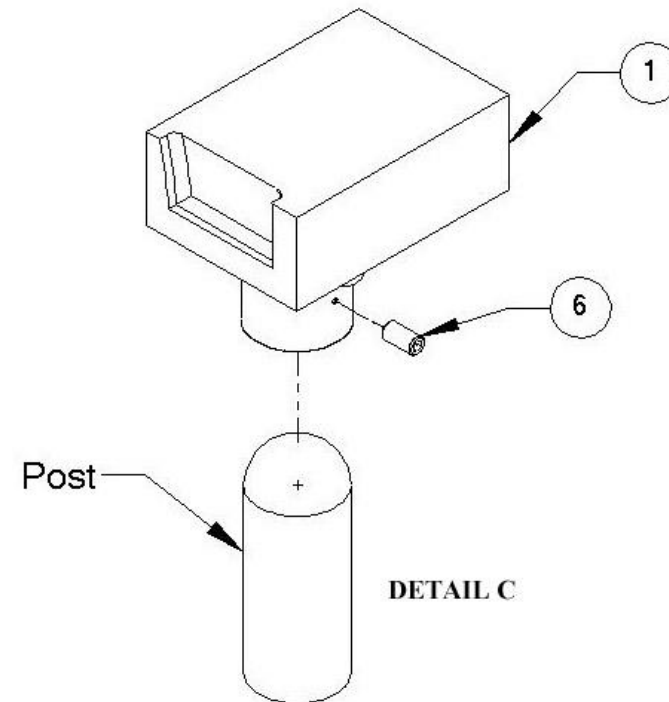



THIS PAGE WAS INTENTIONALLY LEFT BLANK



VALUE SERIES INSTALLATION APPENDIX

INSTALLATION APPENDIX



VALUE SERIES INSTALLATION APPENDIX

Loose fill surfacing material must be maintained at the required depth within the use zone. Loose fill material must be replaced or added as necessary to maintain its resilient properties.

FINAL INSTALLATION STEPS

__1. Once the entire playground has been assembled level and square each post, deck and component.

__2. Tighten all hardware.

__3. Starting at the center of the structure and working out towards the perimeter of the structure, pour concrete into footing holes. Leave 2” from the top of the hole to the top of the concrete to allow for backfill. Slope concrete down and away from post to water from seeping between the post and the concrete. Refer to the footing sections in the individual component instructions for a cutaway drawing.

__4. Clean off any concrete that may have splashed onto equipment before it dries.

__5. After the concrete has set for a minimum of 48 hours (refer to manufacturers instructions for proper cure time) you should backfill the holes. Also, remove any concrete that is not in the holes so they don’t become a hazard for children.

__6. Install labels as instructed on the next page.

__7. Install Surfacing. A protective surfacing material is required under and around all play equipment within the use zone. If using loose fill surfacing, we recommend a depth of 12” for the entire use zone.



VALUE SERIES INSTALLATION APPENDIX

LABEL INSTALLATION

SportsPlay Equipment Inc. has included multiple labels that must be installed on the playground structure as recommended by ASTM.

There are four different labels that, as the owner you are required to install and maintain. If a label becomes damaged please contact your distributor for replacement.

- 1) Warning label – Qty 4
- 2) Supervision and Age Appropriateness – Qty 4
- 3) Manufacturers Identification – Qty 4
- 4) Safety Surfacing – Qty 1 label per post

__1. Identify the proper location. The image to the right shows the proper placement for the labels on the playground post. With the exception of the surfacing labels all labels must be placed between 48” and 60” from the top of the surfacing on the main posts in a conspicuous location, on all four sides of the playground that will be visible to adults.

The surfacing labels shall be placed so that the arrows on the label are level with the top of the recommended surfacing.

__2. Apply. Once you have identified the proper location for the labels ensure that the location is clean and dry, remove the backing from the label and attach them to the post. Smooth out any wrinkles or bubbles by rubbing the backing piece on the surface of the label.

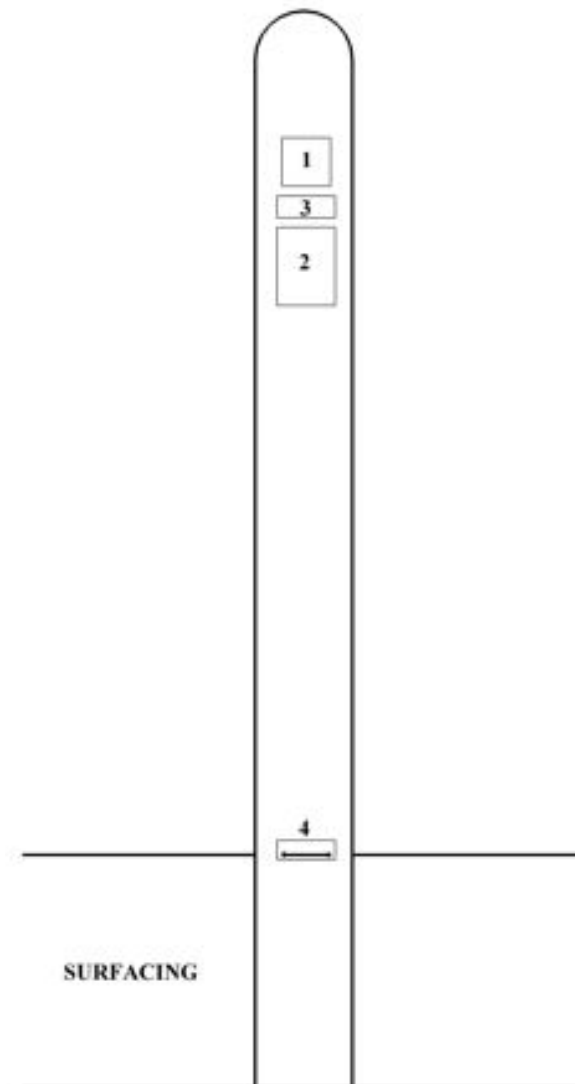



MAINTENANCE AND INSPECTION PROCEDURES

An inspection and maintenance program is a requirement for all playground equipment. As the owner/operator you are responsible for developing a comprehensive inspection and maintenance program for each piece of equipment you own.

Daily inspections of all play areas and equipment for potential hazards is recommended. Pay special attention to moving parts and other components that are expected to wear. Also inspect for foreign debris (broken glass, nails, sharp metal) that could cause injury in and around all play areas.

At a minimum inspections should be scheduled and performed based on the component maintenance requirements. Inspection is not enough, you must perform necessary maintenance when a problem is identified and the equipment must be taken out of service until it is corrected.

A person familiar with the equipment should perform inspections and maintenance.

The component maintenance sheets and a general inspection checklist are included in the next section of this booklet and as the owner it is your responsibility to ensure that you have a copy of each sheet for each component on your playground. If you require additional maintenance sheets simply contact your distributor for a new copy.

All documents that have been included are originals and you will need to make copies to use while performing the inspections and any required maintenance.

All completed forms should be put on file or you may want to insert them at the end of this manual.

Before making copies, note the site location and identify which playground each form is for, on the form itself to prevent using the forms from this playground on equipment from another playground.

SURFACING

Surfacing should be inspected regularly (daily) to ensure that the required surfacing has not been displaced. Displaced surfacing should be raked back into its proper place to maintain the required depth.

Things to look for during inspection:

1. Heavy traffic areas (swings and slide exits) which are prone to surfacing displacement
2. Standing water: Surfacing compacts much faster when wet.
3. Most loose fill surfacing will no longer function as a protective surfacing when frozen.

SportsPlay Equipment does not manufacture surfacing and is only providing this information on surfacing as a guide for safety. Please contact the manufacturer of your surfacing for a complete guide on surfacing inspection and maintenance



VALUE SERIES INSTALLATION APPENDIX

UNDERSTANDING THE MAINTENANCE FORMS

The first form is the General Inspection checklist. This form will cover the basic inspection of the play equipment and area. SportsPlay recommends performing this inspection daily as it covers basic safety of the equipment and area. Documenting this inspection is up to you but you can simply laminate a copy and mark each item with a dry erase marker before allowing access to the area.

After the general maintenance checklist you will find the component maintenance forms. There are two types of components maintenance forms. The first type covers common components or items found on all playgrounds SportsPlay Equipment manufactures (ex: main posts, labels, four hole brackets, footings etc...). The other type of component maintenance forms is specific to the components found on your playground (specific slide, climber, etc...).

Each component form has two sections. The first gives details about what to look for and how to make repairs (not all problems can be repaired in the field) and the second part is the form you will use while performing the inspection/maintenance. The second part includes the inspection checklist and recommended frequency along with a spot to document the date, pass or fail and a signature line for the inspector. If repairs were required there is a spot to list the problem and the action taken. Once these forms have been completed you should either insert them into the back of this manual or keep them on file elsewhere.

Remember that the documents furnished are the originals and copies should be made to use for the actual inspection.



VALUE SERIES INSTALLATION APPENDIX

ORIGINAL INSPECTION AND MAINTENANCE FORMS



VALUE SERIES INSTALLATION APPENDIX

GENERAL INSPECTION CHECKLIST

Adequate surfacing under and around equipment

- Surfacing material is in good condition
- Ensure surfacing materials are not compacted (rake and fluff if necessary)
- Inspect and remove all foreign objects from play area
- No sharp edges on equipment
- No missing pieces of equipment
- No protruding bolts
- No potential clothing entrapments
- All safety guards are in place
- No open crush or shearing points on moving parts
- Inspect and remove or fix all trip hazards (rocks or exposed footings)

- No loose or missing hardware
- Moving parts (example: swings) are not worn
- Swing chains are not looped over the top bar of the swing set
- There are no modifications to the playground
- No strings or rope tied to the equipment
- No liter, tree branches or other debris in and around the play area
- No obvious damage to the play equipment
- Equipment is securely installed
- Windows and bubbles are securely installed with no sign of wear
- Equipment appears to be installed level and square (no obvious tilt or lean)

Inspect all posts for the following:

- Verify that all hardware is in place and secure
 - Bolts & Nuts – Snug tight and then tighten an additional $\frac{1}{4}$ turn
 - Set Screws – Snug tight and then tighten an additional full turn
 - Should you discover hardware is broken or missing order replacement parts immediately Refer to the component installation instructions for part identification
- You will perform this inspection when performing your component inspections

Replacement Parts

- Contact your distributor to order new labels. If unable to contact distributor please call SportsPlay Equipment for replacements: 1-314-389-4140
- Before calling be sure to identify the proper part, part number and quantity needed
- When ordering replacement hardware you need to order replacement tools since most hardware is tamper resistant

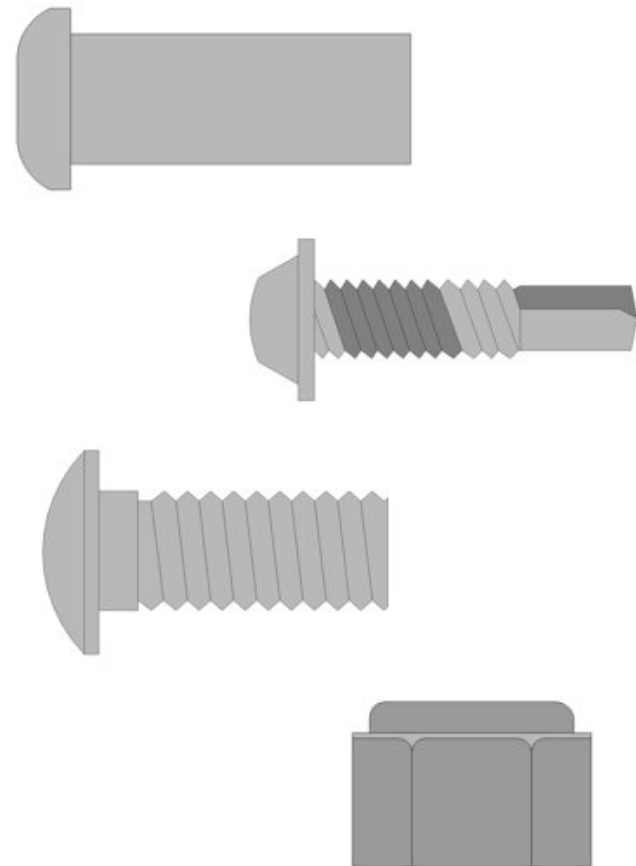

Footings

- Move surfacing (if loose fill) to expose the footing
- Inspect concrete for cracks or loose supports
 - If cracked footings or loose supports are found you must excavate the soil around the concrete, remove the concrete and pour a new footing
- Replace or move the surfacing back into position and verify correct surfacing levels are maintained in and around the play equipment

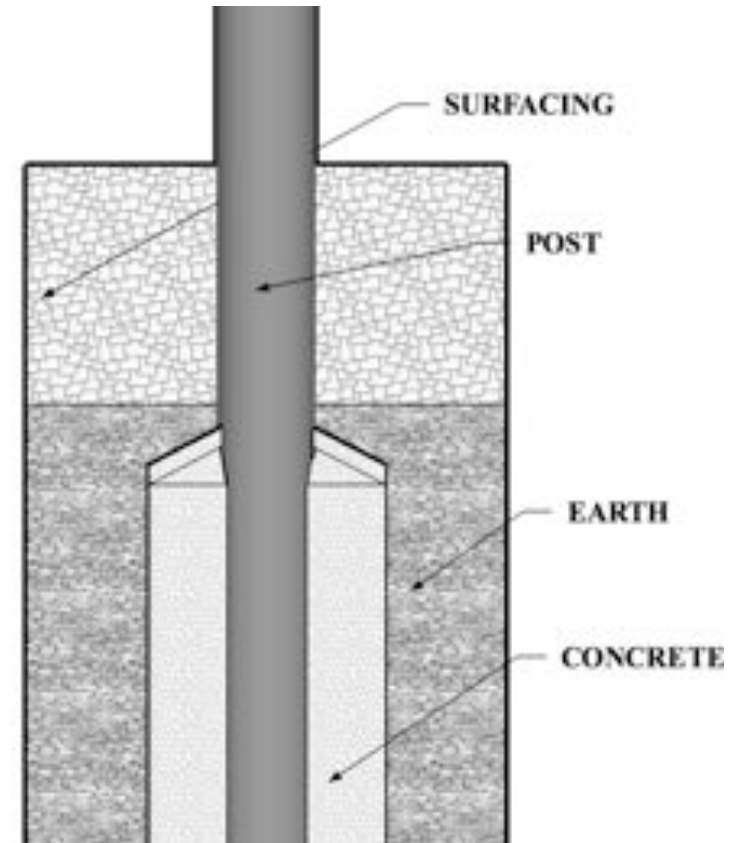



INSPECTION FORM

- MAKE COPIES OF THIS FORM TO USE FOR INSPECTION
- REVIEW THE “MAINTENANCE GUIDE” IN THE APPENDIX TO BETTER UNDERSTAND THE IMPORTANCE OF MAINTENANCE AND HOW TO DEVELOP A MAINTENANCE SCHEDULE.
- DOCUMENT ALL MAINTENANCE ACTIONS ON THE LIST AS WELL AS ANY NOT LISTED.
- INCLUDE DATES AND SIGNATURES

Inspection Checklist	Recommended Frequency	Grade (Pass/Fail/NA)	Date Inspected	Date Repairs Completed
Inspect footings for cracks	Yearly			
Inspect footings for loose supports	Yearly			

Inspector: _____ Signature: _____ Date: _____

Maintenance Record			
Part	Problem	Corrective Action	Date

Inspect all four labels at all locations for the following:

- The labels are present
- The labels are not worn
- There are Manufactures id, age group and warning labels (labels 1-3 on the drawing to the right) on all four sides at eye level.
- Each post shall have a surfacing level label (label 4 on the drawing) at the proper position on the post
- If any of the labels are worn or missing order replacements

Installing new labels

- Clean the surface where the label is being applied
- Allow surface to dry
- Apply label
- Use the label backing material to smooth out all wrinkles and bubbles

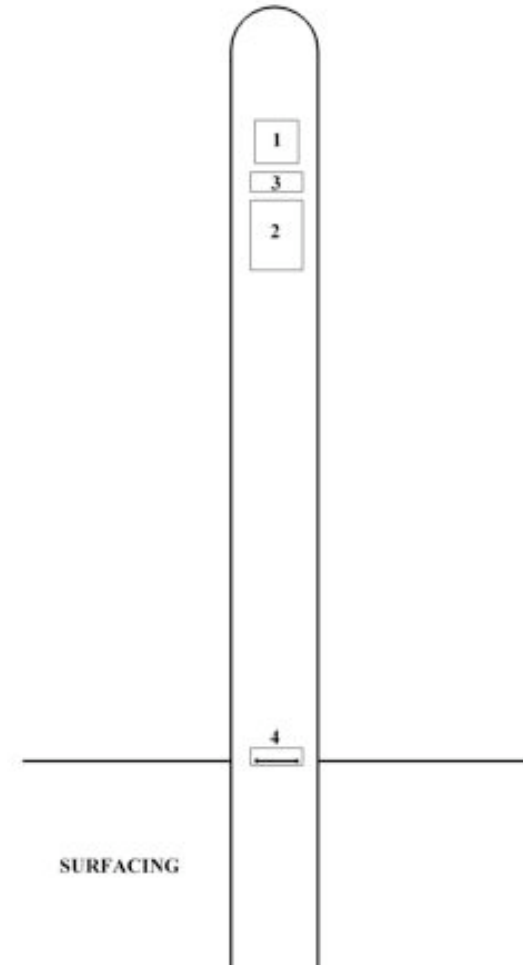

Replacement Parts

- Contact your distributor to order new labels. If unable to contact distributor please call SportsPlay Equipment for replacements: 1-314-389-4140



INSPECTION FORM

- MAKE COPIES OF THIS FORM TO USE FOR INSPECTION
- REVIEW THE “MAINTENANCE GUIDE” IN THE APPENDIX TO BETTER UNDERSTAND THE IMPORTANCE OF MAINTENANCE AND HOW TO DEVELOP A MAINTENANCE SCHEDULE.
- DOCUMENT ALL MAINTENANCE ACTIONS ON THE LIST AS WELL AS ANY NOT LISTED.
- INCLUDE DATES AND SIGNATURES

Inspection Checklist	Recommended Frequency	Grade (Pass/Fail/NA)	Date Inspected	Date Repairs Completed
Inspect Labels	Monthly			

Inspector: _____ Signature: _____ Date: _____

Maintenance Record			
Part	Problem	Corrective Action	Date

Inspect all posts for the following:

- Verify all posts are securely installed in the concrete footing
 - Review the footing maintenance document for repair procedure should you discover a post is not secure
- Inspect paint for damage, if damaged:
 - If powder coating needs to be repaired sand surface and mask off area. Coat with primer and once the primer has dried paint with color matching touch up paint. Contact distributor of color matching paint.
- Verify there are no sharp edges
 - If there are sharp edges or gouges smooth them down and touch up the paint using the procedure above

Replacement Parts

- Contact your distributor to order new labels. If unable to contact distributor please call SportsPlay Equipment for replacements: 1-314-389-4140

LABELS

- Should you discover a damaged label during inspection, review the label maintenance sheet for instructions on how to replace them.

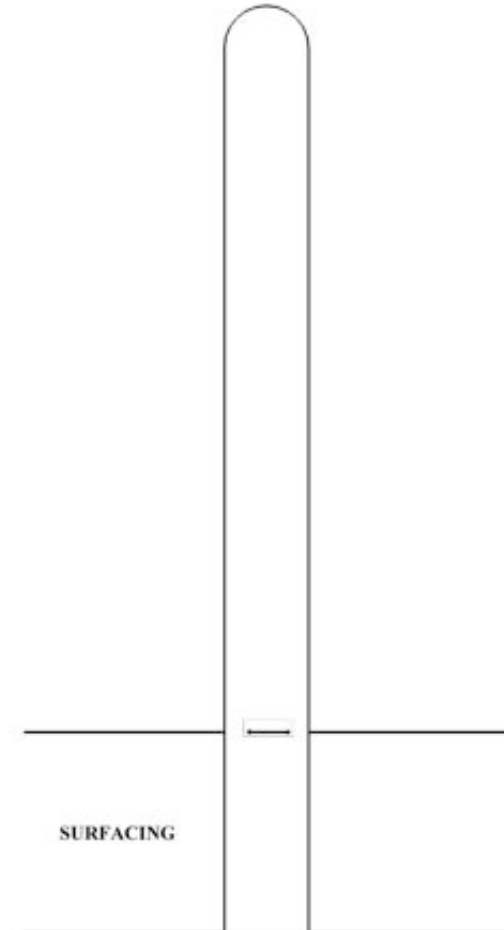



INSPECTION FORM

- MAKE COPIES OF THIS FORM TO USE FOR INSPECTION
- REVIEW THE “MAINTENANCE GUIDE” IN THE APPENDIX TO BETTER UNDERSTAND THE IMPORTANCE OF MAINTENANCE AND HOW TO DEVELOP A MAINTENANCE SCHEDULE.
- DOCUMENT ALL MAINTENANCE ACTIONS ON THE LIST AS WELL AS ANY NOT LISTED.
- INCLUDE DATES AND SIGNATURES

Inspection Checklist	Recommended Frequency	Grade (Pass/Fail/NA)	Date Inspected	Date Repairs Completed
Inspect posts for damage	Monthly			
Verify posts are secure in footings	Monthly			

Inspector: _____ Signature: _____ Date: _____

Maintenance Record			
Part	Problem	Corrective Action	Date

Deck Attachment

- Ensure deck is securely attached to post and all hardware is in place and in good condition

Hardware

- Inspect for loose or missing hardware. Tighten all loose hardware and replace all missing hardware. Block off access to equipment if necessary.
- Order new hardware from SportsPlay Equipment Inc.

Welds

- Inspect all welds for cracks. If a crack is found block access to the playground and contact your distributor for replacement parts immediately.

Finish

- Inspect all metal components for coating damage. If powder coating needs to be repaired sand surface and mask off area. Coat with primer and once the primer has dried paint with color matching touch up paint. Contact distributor of color matching paint. Contact Distributor for Thermoplastic repair kit.

Surfacing - Refer to the surfacing maintenance sheet.

Replacement Parts

- Reference the parts list on page 2 of the instruction set for this component to identify the part/s correctly.
- Contact your distributor to order parts.

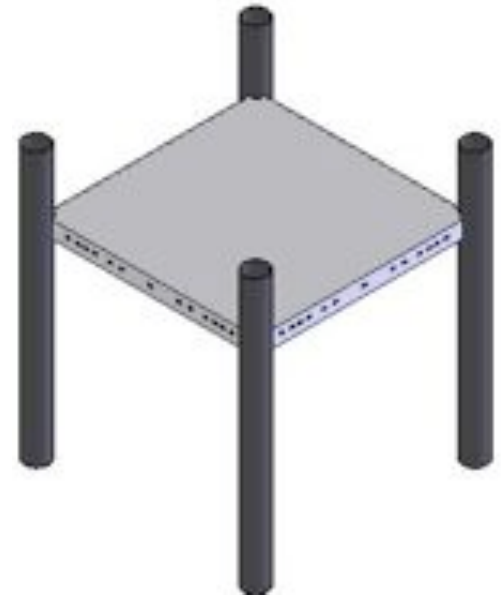

Deck Attachment

- Ensure deck is securely attached to post and all hardware is in place and in good condition

Hardware

- Inspect for loose or missing hardware. Tighten all loose hardware and replace all missing hardware. Block off access to equipment if necessary.
- Order new hardware from SportsPlay Equipment Inc.

Welds

- Inspect all welds for cracks. If a crack is found block access to the playground and contact your distributor for replacement parts immediately.

Finish

- Inspect all metal components for coating damage. If powder coating needs to be repaired sand surface and mask off area. Coat with primer and once the primer has dried paint with color matching touch up paint. Contact distributor of color matching paint. Contact Distributor for Thermoplastic repair kit.



Surfacing - Refer to the surfacing maintenance sheet.

Replacement Parts

- Reference the parts list on page 2 of the instruction set for this component to identify the part/s correctly.
- Contact your distributor to order parts.

Brackets

- Inspect all four-hole clamps and panel clamps.
- Ensure the setscrews are tight and in place.
- Ensure all Torx Screws are in place and that the bracket is firmly attached to post.
- Inspect the clamps for cracks and sharp edges. Smooth any sharp edges and fix the finish. Replace brackets if cracked.

Hardware

- Inspect for loose or missing hardware. Tighten all loose hardware and replace all missing hardware. Block off access to equipment if necessary.

Welds

- Inspect all welds for cracks. If a crack is found block access to the playground and contact your distributor for replacement parts immediately.

Finish

- Inspect all metal components for coating damage. If powder coating needs to be repaired sand surface and mask off area. Coat with primer and once the primer has dried paint with color matching touch up paint. Contact distributor of color matching paint. Contact Distributor for Thermoplastic repair kit.

Surfacing - Refer to the surfacing maintenance sheet.

Footings

- Inspect all footings to ensure equipment is secure. You must block access to prevent access until repair is made.



Replacement Parts

- Reference the parts list on page 2 of the instruction set for this component to identify the part/s correctly.
- Contact your distributor to order parts.

Brackets

- Inspect all four-hole clamps and panel clamps.
- Ensure the setscrews are tight and in place.
- Ensure all Torx Screws are in place and that the bracket is firmly attached to post.
- Inspect the clamps for cracks and sharp edges. Smooth any sharp edges and fix the finish. Replace brackets if cracked.

Hardware

- Inspect for loose or missing hardware. Tighten all loose hardware and replace all missing hardware. Block off access to equipment if necessary.

Plastic Components

- Inspect for any sharp edges or deformities. Minor deformities and sharp edges can be repaired using a utility knife. Block off access until repairs are made. Contact distributor for replacement parts.

Welds

- Inspect all welds for cracks. Block access to the playground and contact your distributor for replacement parts immediately.

Finish

- Inspect all metal components for coating damage. If powder coating needs to be repaired sand surface and mask off area. Coat with primer and once the primer has dried paint with color matching touch up paint. Contact distributor of color matching paint. Contact Distributor for Thermoplastic repair kit.

Surfacing - Refer to the surfacing maintenance sheet.

Slide

- Refer to “Plastic Components” section.
- Inspect run-out section of the slide for standing water. Adjust the slide by digging up existing footing and install it slightly lower to increase the slope of the slide.

Footings

- Inspect all footings to ensure equipment is secure. You must block access to prevent access until repair is made.

Replacement Parts

- Reference the parts list on page 2 of the instruction set for this component to identify the part/s correctly.
- Contact your distributor to order parts.

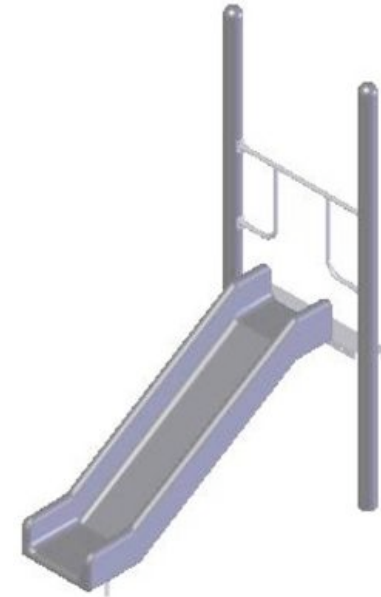

Brackets

- Inspect all four-hole clamps and panel clamps.
- Ensure the setscrews are tight and in place.
- Ensure all Torx Screws are in place and that the bracket is firmly attached to post.
- Inspect the clamps for cracks and sharp edges. Smooth any sharp edges and fix the finish. Replace brackets if cracked.

Hardware

- Inspect for loose or missing hardware. Tighten all loose hardware and replace all missing hardware. Block off access to equipment if necessary.

Plastic Components

- Inspect for any sharp edges or deformities. Minor deformities and sharp edges can be repaired using a utility knife. Block off access until repairs are made. Contact distributor for replacement parts.

Welds

- Inspect all welds for cracks. If a crack is found block access to the playground and contact your distributor for replacement parts immediately.

Finish

- Inspect all metal components for coating damage. If powder coating needs to be repaired sand surface and mask off area. Coat with primer and once the primer has dried paint with color matching touch up paint. Contact distributor of color matching paint. Contact Distributor for Thermoplastic repair kit.

Surfacing - Refer to the surfacing maintenance sheet.

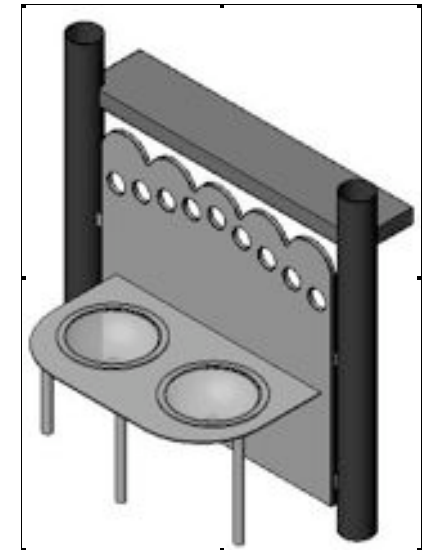

Footings

- Inspect all footings to ensure equipment is secure. You must block access to prevent access until repair is made.

Replacement Parts

- Reference the parts list on page 2 of the instruction set for this component to identify the part/s correctly.
- Contact your distributor to order parts.

Brackets

- Inspect all four-hole clamps and panel clamps.
- Ensure the setscrews are tight and in place.
- Ensure all Torx Screws are in place and that the bracket is firmly attached to post.
- Inspect the clamps for cracks and sharp edges. Smooth any sharp edges and fix the finish. Replace brackets if cracked.

Hardware

- Inspect for loose or missing hardware. Tighten all loose hardware and replace all missing hardware. Block off access to equipment if necessary.

Plastic Components

- Inspect for any sharp edges or deformities. Minor deformities and sharp edges can be repaired using a utility knife. Block off access until repairs are made. Contact distributor for replacement parts.

Welds

- Inspect all welds for cracks. If a crack is found block access to the playground and contact your distributor for replacement parts immediately.

Finish

- Inspect all metal components for coating damage. If powder coating needs to be repaired sand surface and mask off area. Coat with primer and once the primer has dried paint with color matching touch up paint. Contact distributor of color matching paint. Contact Distributor for Thermoplastic repair kit.

Surfacing - Refer to the surfacing maintenance sheet.

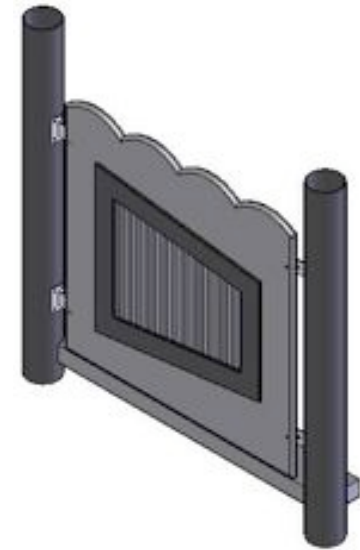

Footings

- Inspect all footings to ensure equipment is secure. You must block access to prevent access until repair is made.

Replacement Parts

- Reference the parts list on page 2 of the instruction set for this component to identify the part/s correctly.
- Contact your distributor to order parts.

Brackets

- Inspect all four-hole clamps and panel clamps.
- Ensure the setscrews are tight and in place.
- Ensure all Torx Screws are in place and that the bracket is firmly attached to post.
- Inspect the clamps for cracks and sharp edges. Smooth any sharp edges and fix the finish. Replace brackets if cracked.

Hardware

- Inspect for loose or missing hardware. Tighten all loose hardware and replace all missing hardware. Block off access to equipment if necessary.

Plastic Components

- Inspect for any sharp edges or deformities. Minor deformities and sharp edges can be repaired using a utility knife. Block off access until repairs are made. Contact distributor for replacement parts.

Welds

- Inspect all welds for cracks. If a crack is found block access to the playground and contact your distributor for replacement parts immediately.

Finish

- Inspect all metal components for coating damage. If powder coating needs to be repaired sand surface and mask off area. Coat with primer and once the primer has dried paint with color matching touch up paint. Contact distributor of color matching paint. Contact Distributor for Thermoplastic repair kit.

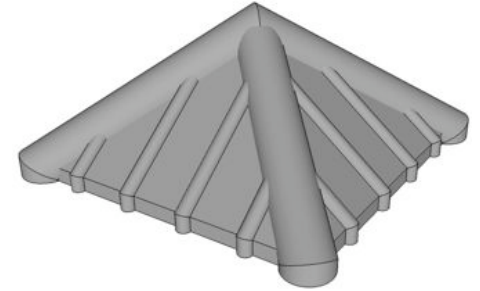

Surfacing - Refer to the surfacing maintenance sheet.

Slide

- Refer to “Plastic Components” section.
- Inspect run-out section of the slide for standing water. Adjust the slide by digging up existing footing and install it slightly lower to increase the slope of the slide.

Footings

- Inspect all footings to ensure equipment is secure. You must block access to prevent access until repair is made.

Replacement Parts

- Reference the parts list on page 2 of the instruction set for this component to identify the part/s correctly.
- Contact your distributor to order parts.



VALUE SERIES INSTALLATION APPENDIX

COMPLETED INSPECTION AND MAINTENANCE FORMS